

# Synchronized Slotting/Milling

- Fits most multiple spindle automatics
- Heavy-Duty All Bearing Construction
- 1/2" Wide Cutter Width
- Easy installation
- Hardened & Ground Components
- Face Plate System allows Support Bushings
- Robust Dual Supported Cutter Shaft
- High Pressure Coolant Ports
- Heat-Treat Gear System
- Tramble Way Plate System
  - No Boring required
- Attachment Drive Unit is included
- Attachment Top RPM = Machine Top RPM

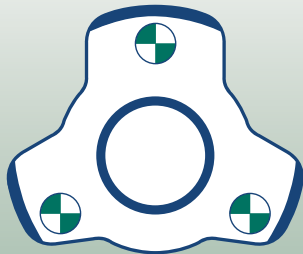
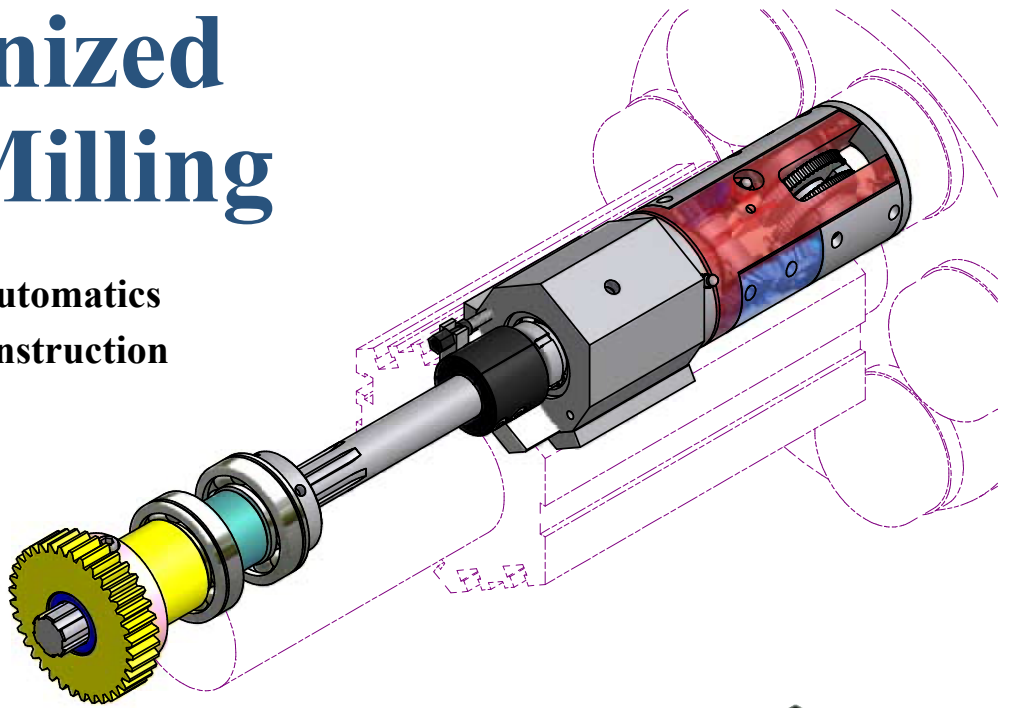

**BME** INC.  
*Screw Machine Solutions*

*Quality you deserve.*

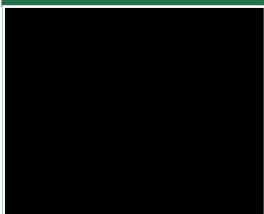

**MADE  
IN THE  
U.S.A.**