

Heavy Duty Cross Slide Polygon/ Thread Milling

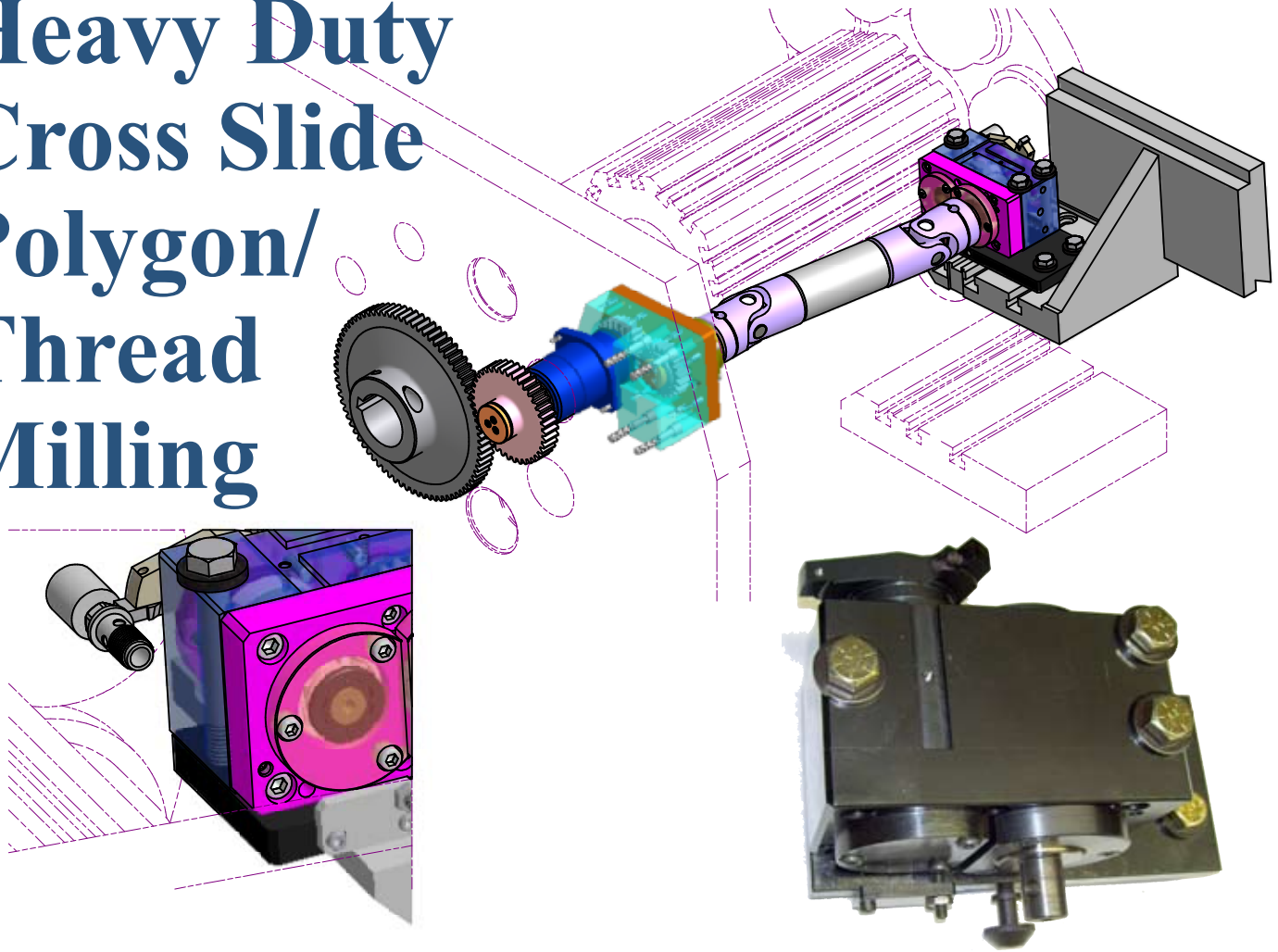

- One attachment does both the Thread Mill and Polygon
- Heavy-Duty Polygon allows machining in steel
- Attachment Drives 1-to-1 or 2-to-1 with change gears
- Heat-Treated gears and components
- Sealed Cutter Box and Transmission with constant lubrication
- Drives off standard Pickoff Gear
- Polygon cutters use inserts
- Attachment fits multiple position with only changing the base plates
- Industry leading Thread Mill Attachment has taper adjustment for exact pitch straightness



www.bmeattachments.com

Office 810.937.2974 / Fax 810.937.2975