

BME INC.

Screw Machine Attachments

2019

**Tool Holders &
Attachments**

*Providing quality attachments for any screw
machine challenge through original innovative
design and engineering, with proven results!*



SCHLITTER
we tool your world



About BME..

BME is a Screw Machine Rebuilder and Custom tooling supplier located in southeast Michigan. Founded on the principle that quality attachments and accessories for multi spindles can be manufactured and supported right here in our own country. We pride ourselves on our quality of work and exceeding our customer's expectations. Founded, in 2007, BME provided attachments for Acme-Gridley's, mainly Flat Generators and Sync attachments, but over the years we've expanded our product line to include attachments for New Britains, Wickmans, Davenports, and any multi-spindles we've been maintaining steady growth while continuing to expand our knowledge and skill base. Our growth over the years has also led to the purchase and integration of Precision Form and Grind, and in 2016, Schlitter Tool/ Genius Inc product line.

We attribute a majority of this growth to our ability to solve the screw machine industries' challenges, along with our commitment to our customers, and meeting their deadlines. Our 15,000 square foot facility also contains a variety of CNC manufacturing equipment, that allows us to manufacture a majority of components in house. Our staff includes personnel that have a combined 80 plus years of experience in diagnosing, designing, and debugging a variety of solutions to customer challenges on screw machines.

Have you ever been told that "you can't do that on a screw machine"? Give us a call and let us solve your problems!

Why BME?

- Our engineering is unsurpassed, with years of experience working on machines and attachments to blend with years of experience in mechanical design.
- The most advanced software is used to create systems that meet customer requirements to perform the demanding needs of today's manufacturing.
- We communicate effectively with our customer, which reduces errors and delivers a better, innovative product faster.
- Our attachments save our customers money by allowing complete processing. A part that is manufactured completely in one step without a secondary operation allows an unmatched advantage, increasing profits and quality. The less a part is handled, the more cost effective the process!
- We stand by our product, we won't sell an attachment that we don't feel confident will solve the customer's problem.
- In most applications, we offer a 30 day trial (except custom components) before invoicing.
- Our products are designed and manufactured to have replaceable components, with minimal fitting spacers, for quick replacements.
- Our products are designed and manufactured to endure heavy loading and usage, hardened and ground components, and utilizing spline drives in place of keys.
- Our products are domestically manufactured and stocked on our floor, minimizing lead times for both new purchases and replacement parts.

The following catalog is a list of common Tool Holders, Attachments and Cut Off Tooling, but if you don't see what you are looking for, please contact us! We have been providing more than just tooling to our customers for over 10 years. We provide solutions to the everyday challenges of the multi-spindle user. This is just a fraction of the tooling we supply. Also, please review our website, we are constantly adding new product.

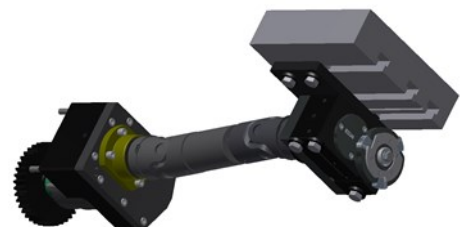
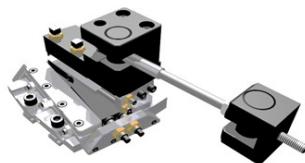
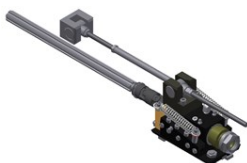

Table of Contents

Universal Holders	
Boring	5
Broaching Internal and External	6
Floating Reamer Holders	7
Floating Tap Holders	8
Tool Slide Mounted Roll Supports	
Nat'l Acme Six Spindle	9
Nat'l Acme Eight Spindle	10
New Britain	11
Wickman	12
Recessing	
Recess Tool Holders, Shank Style (all machines)	14
Adjustable Stationary and Recess Milling Attachments All Machines	15
Davenport Push Type Rotary Recess Mill	16
Shave Heads	
Shave Holders Pin Type,G Type, Model B Shank	18
Shave Holder Mount Blocks	
Nat'l Acme Six Spindle	18
Nat'l Acme Eight Spindle	19
New Britain	20
Wickman	22
Shave Holders Model B Type	
Nat'l Acme Model B Type Shave Assy	24
New Britain Model B Type Shave Assy	24
Wickman Model B Type Shave Assy	25
Davenport Shave Heads	
Shave Roll Supports	
Nat'l Acme Six Spindle	27
Nat'l Acme Eight Spindle	27
New Britain	28
Wickman	28
Perishable Tooling - Do it yourself Inserts	
Flat Generating All Machines	
Synchronous ETS Cross Drill All Machines	
Synchronous ETS Milling All Machines	
Air Operated Pick Off Assy - New Britain	
Cross Slide Recess Attachments	
Ball Bearing HSDA Spindles	



Boring

Newly redesigned, this holder is now available in four shank sizes and three tool bores to give you the flexibility you need.

Tool Bore	1000 Series Low Profile			
	3/4 shank	1 shank	1 1/4 shank	
1/2	BOR1075A	BOR1100A	BOR1125A	
5/8	BOR1075B	BOR1100B	BOR1125B	
3/4	BOR1075C	BOR1100C	BOR1125C	
1	BOR1075D	BOR1100D	BOR1125D	
2000 Series High Capacity				
Tool Bore	1 1/2 shank	1 3/4 shank	2 shank	2 1/2 shank
1	BOR2150D	BOR2175D	BOR2200D	BOR2250D
1 1/8	BOR2150E	BOR2175E	BOR2200E	BOR2250E
1 1/4	BOR2150F	BOR2175F	BOR2200F	BOR2250F

Broaching

Our Broaching attachment is engineered to outperform every other holder made. From the heavy-duty bearings to the tool knock-out hole, our holder is designed to keep your machine operating at peak efficiency. You'll be surprised how easy it is to create ID shapes right on your screw machine. Order yours today! Looking for Driven Broaching Attachments, please contact us today! HexMaster™ saves time and money by machining a high-quality hex or other shape into your brass, steel or aluminum part in just seconds! HexMaster™ eliminates secondary operations and frees machines and people for other tasks. HexMaster™ is ideal for screw machines, CNC's, or manual machines. Works equally well on turning and milling machines. HexMaster™ works like a high speed chisel, cutting a precision shape into the ID or OD of your workpiece. Setup is as easy as centering the tool on the work. Quick change design makes tool change quick and reliable. HexMaster™'s unique tool knock-out hole makes ejecting a broken tool quick and easy. Even our standard holder is heavy-duty. HexMaster™ has been engineered to outlast and outperform all of its competition. Bearings have been carefully selected which provide 150% the capacity of its closest competitor. All wear surfaces are hardened and ground. The ID holder is available in heavy duty and ultra heavy duty models with six shank sizes and three tool bores. Tools can be purchased direct from Schlitter Tool or from third party sources. HexMaster™'s design has been proven in the most grueling production environment available: the production screw machine industry. This product works so well that we use it in our own fabrication processes. Our holders function through three shifts a day, seven days a week and perform with gusto! Advanced computer design and state-of-the-art manufacturing allow us to offer you this unique attachment at very economical prices. Our efficiency is your savings. Don't get gouged by the competition, order a HexMaster™ today!

- Create a high quality hex in seconds
- Eliminate secondary work and handling
- Expand your shop's capabilities
- Use on CNC lathes, screw machines, manual lathes and machining centers
- High performance bearings outperform the competition's
- Unique tool knock-out hole and easy setup



HexMaster™ ID Holders

Shank Diameter	Diameter of Tool Shank		Diameter of Tool Shank	
	.315	.500	.500	.750
5/8	HM1062A	HM1062B	n/a	n/a
3/4	HM1075A	HM1075B	n/a	n/a
1	HM1100A	HM1100B	n/a	n/a
1 1/4	HM1125A	HM1125B	HM2125B	HM2125C
1 1/2	n/a	n/a	HM2150B	HM2150C
1 3/4	n/a	n/a	HM2175B	HM2175C
2	n/a	n/a	HM2200B	HM2200C

HexMaster™ OD Holders



Shank Diameter	1.5748" dia. tool blank	.9448" dia. tool blank
16mm	n/a	HM4016E
5/8	n/a	HM4625E
3/4	HM3075E	HM4075E
1	HM3100E	n/a
1 1/4	HM3125E	n/a
1 1/2	HM3150E	n/a
2	HM3200E	n/a

If you need a size not listed above, call us and we can make you a special holder to exactly suit your needs.

The best known, most innovative companies in the world rely on BME Inc. for their tooling needs. When you need tooling, give us a call at 1.810.937.2974 or check us out online at www.bmeattachments.com.

Precision Form & Grind Floating Reamer Holder

Here is indeed an outstanding floating tool holder! Its simplicity of design (a coordination of only five parts) bespeaks its high efficiency. It will compensate for both angular and parallel misalignment, permits the float to be adjusted in all directions. The moving parts ride on rollers and thus contribute immeasurably to making the members antifriction-producing smoother running with more perfect alignment. Composed of only 5 parts, the Precision Floating Tool Holder requires a minimum of maintenance-nothing to get out of order. Nor is there anything to fall out or get lost when holder is taken apart. It will enable you to ream holes with close tolerances with the very first hole reamed to size. You will definitely have no more "bell mouthed holes" if you use the Precision Floating Tool Holder.

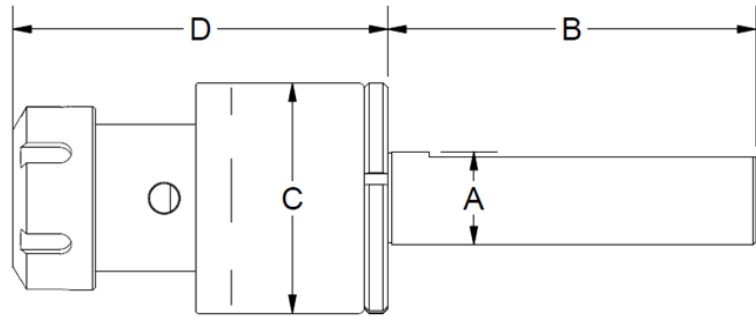

All Holders come with Port for Coolant thru

Specials Available upon Request!

Floating Reamer Holders with ER Collet Seat						
Model No	ER Collet Size	A - Shank Size	B - Shank Length	C - Dia	D - Length	Part #
200	ER 25	3/4"	4"	2.00"	3.06"	200-075
		1"				200-100
		1 1/4"				200-125
		1 1/2"				200-150
250	ER 32	1"	4"	2.47"	4.02"	250-100
		1 1/2"				250-150
		2"				250-200
300	ER 40	1"	4"	2.97"	4.55"	300-100
		1 1/2"				300-150
		2"				300-200
		2 1/4"				300-250

Precision Form & Grind Floating Tap Holders

Designed to correct parallel and angular misalignment. This holder permits the tap to float freely whether going in or OUT, and will not freeze under tension caused by drag of tap. The amount of float is infinitely variable and is simply adjusted by a lock nut. This makes close tolerances on tapped holes easier to hold. There are no spring or pivot members to restrict float. Square hole in collet drive taps.

STRAIGHT HOLE IS GUARANTEED NO BELL MOUTH WILL OCCUR



Purchase of Holder comes with (1) Collet, customer to specify part # at time of order

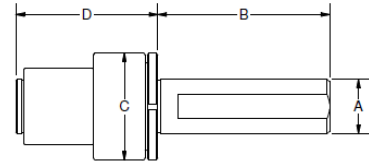

Floating Tap Holders						
Model No	Tap Sizes	A - Shank Size	B - Shank Length	C - Dia	D - Length	Part #
1200	3/16" to 1/2" Inclusive, STD 1/8" Pipe Tap	1"	4"	2.00"	3.06"	1200-100
		1 1/2"				1200-125
		1 3/4"				1200-150
1250	1/2" to 1 1/4" Inclusive STD Pipe Taps 1/4" to 5/8"	1"	4"	2.50"	3.06"	1250-100
		1 1/4"				1250-125
		1 1/2"				1250-150
1300	1 1/4" to 1 3/4" Inclusive, STD Pipe Taps 3/4" to 1 1/4"	1 1/4"	4"	3.00"	3.8125"	1300-125
		1 1/2"				1300-125
		1 3/4"				1300-175
		2"				1300-200

1200 Series Collets									
Part #	Tap Size	Part #	Tap Size	Part #	Tap Size	Part #	Tap Size	Part #	Tap Size
3068	#4	3054	#12	3087	for .302 dia	3063	15/32	3065	1/8 small pipe
3050	#6	3055	7/32	3059	5/16	3064	1/2	3066	1/8 large pipe
3052	#8	3056	#14	3060	11/32	3085	9/16	3069	1/8 grease pipe tap
3067	#10	3057	1/4	3061	3/8	3091	5/8		
3053	3/16	3058	9/32	3062	13/32 & 7/16				

1250 Series Collets									
Part #	Tap Size	Part #	Tap Size	Part #	Tap Size	Part #	Tap Size	Part #	Tap Size
3300	1/4	3308	21/32	3316	15/16	3324	3/8 pipe	3334	1-14 special
3301	5/16	3309	11/16	3317	1	3325	1/2 pipe	3335	5/8-11
3302	3/8	3310	23/32	3318	1 1/16	3326	3/4 pipe	3336	7/16
3303	1/2	3311	3/4	3319	1 1/8	3327	5/8 pipe	3338	15/64 tap
3304	17/32	3312	25/32	3320	1 3/16	3329	9/16 and 11/16	3339	1/8 pipe & 1/8 sm
3305	9/16	3313	13/16	3321	1 1/4	3331	11/32 tap	3340	#10
3306	19/32	3314	27/32	3322	1/8 pipe	3332	13/32 tap		
3307	5/8	3315	7/8	3323	1/4 pipe	3333	7/16 tap		

1300 Series Collets									
Part #	Tap Size	Part #	Tap Size	Part #	Tap Size	Part #	Tap Size	Part #	Tap Size
3449	5/8	3456	1 7/16	3463	7/8 pipe	3493	1 7/32	3506	3/8
3450	1	3457	1 1/2 and 1 1/16	3464	1 pipe	3494	1 19/32	3507	3/4
3451	1 1/16	3458	1 5/8	3465	1 1/4 pipe	3495	1 3/16	3512	1 1/2 pipe
3452	1 1/8	3459	1 3/4	3467	7/8	3496	1 9/16-18	3515	1/2 tap
3453	1 1/4	3460	1 7/8	3468	5/16	3498	5/8 pipe	3309	11/16
3454	1 5/16	3461	1/2 Pipe	3478	1 9/16	3499	1/4 pipe	3313	13/16
3455	1 3/8	3462	3/4 pipe	3479	1 11/16	3500	3/8 pipe	3316	15/16

Visit us Online at www.bmeattachments.com
3763 Lapeer Rd, Suite E— Port Huron, MI 48060
Office 810-937-2974 / Fax 810-937-2975

Roll Supports Six Spindle National Acme

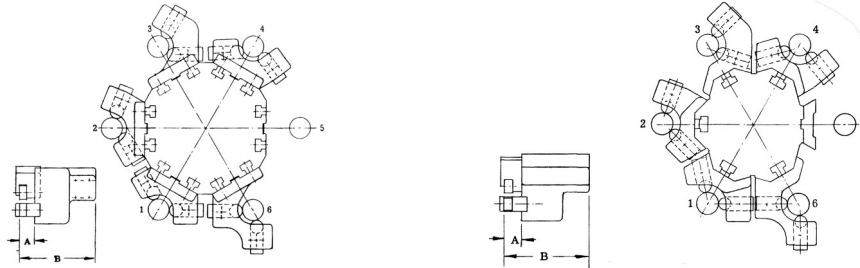

	Machine	Position	Standard Capacity		Small Capacity	
			Order #	Capacity	Order #	Capacity
Angular Base	9/16 & 1 RA	1	10-3	1/4 - 1	10-3A	1/8 - 3/8
		2, 4	10-38	1/4 - 1	10-38A	1/8 - 3/8
		3	10-5	1/4 - 1	10-5A	1/8 - 3/8
		6	10-25	1/4 - 1	10-25A	1/8 - 3/8
	1 R, RAS 1 1/4 R, RA	1	10-44	5/16 - 1 1/4	10-44A	9/32 - 1 1/8
		2, 4	10-43	5/16 - 1 1/4	10-43A	1/4 - 1 1/8
		3	10-39	5/16 - 1 1/4	10-39A	1/4 - 1 1/8
		6	10-31	5/16 - 1 1/4	10-31A	
	2, 2 1/4, 2 5/8 R, RA	1	10-50	1 1/8 - 2 1/2	n/a	
		2, 4	10-51	1 - 2 5/8	n/a	
		3	10-17	7/8 - 2 1/2	n/a	
		6	10-47	1 1/8 - 2 1/2	n/a	
Flat Base	7/16	1	10-137	3/32 - 7/16	n/a	
		2, 4	10-138	3/32 - 7/16	n/a	
		3	10-139	3/32 - 7/16	n/a	
		6	10-140	3/32 - 7/16	n/a	
	5/8 RN	1	10-175	1/8 - 5/8	n/a	
		2, 3, 4	10-176	1/8 - 5/8	n/a	
		6	10-177	1/8 - 5/8	n/a	
	9/16, 1 RA, RAN	1	10-126	1/4 - 1	10-126A	1/8 - 1
		2	10-127	1/4 - 1	10-127A	1/8 - 1
		3	10-128	1/8 - 1	n/a	
		4	10-129	1/4 - 1	10-129A	1/8 - 1
		6	10-130	1/4 - 1	10-130A	1/8 - 1
	1 1/4 RA, RB	1	10-103	5/16 - 1 1/4	10-103A	1/8 - 3/8
		2, 4	10-104	5/16 - 1 1/4	10-104A	1/8 - 3/8
		3	10-105	5/16 - 1 1/4	10-105A	1/8 - 3/8
		6	10-106	5/16 - 1 1/4	10-106A	1/8 - 3/8
	1 5/8 RA, RB 2 RB, RAS	1	10-34R	1/2 - 2	10-34RA	1/4 - 3/4
		2, 4	10-35R	1/2 - 2	10-35RA	1/4 - 3/4
		3	10-36R	1/4 - 2	n/a	
		6	10-37R	1/2 - 2	10-37RA	1/4 - 3/4
	2 5/8 RB	1	10-83	5/8 - 2 5/8	n/a	
		2, 4	10-48	5/8 - 2 5/8	n/a	
		3	10-84	5/8 - 2 5/8	n/a	
		6	10-49	5/8 - 2 5/8	n/a	
3, 3 1/2 RA, RB	1	10-85	1 1/2 - 3 1/2	n/a		
	2	10-86	1 1/2 - 3 1/2	n/a		
	3	10-87	1 1/2 - 3 1/2	n/a		
	4	10-88	1 1/2 - 3 1/2	n/a		
	6	10-167	1 1/2 - 3	n/a		

Roll Supports Eight Spindle National Acme



Machine	Position	Standard Capacity		Small Capacity	
		Order #	Capacity	Order #	Capacity
3/4 RA	1	10-152	1/4 - 3/4	10-152A	1/8 - 3/8
	2, 5	10-153		10-153A	
	3, 6	10-154		10-154A	
	4, 7	10-155		10-155A	
	8	10-156		10-156A	
1 1/4 RB 1 5/8 RBN	1	10-157	5/16 - 1 1/4	10-157A	1/8 - 5/8
	2, 5	10-158		10-158A	
	3, 6	10-159		10-159A	
	4, 7	10-160		10-160A	
	8	10-161		10-161A	
1 5/8 RA, RB 2 RB	1	10-119	1 1/8 - 2 1/2	10-119A	1/4 - 3/4
	2, 5	10-89	1 - 2 5/8		
	3, 6	10-90	7/8 - 2 1/2		
	4, 7	10-120			
	8	10-121	1 1/8 - 2 1/2	10-121A	
2 1/4, 2 5/8 RA, RB	1	10-91	5/8 - 2 5/8		
	2, 5	10-92	5/8 - 2 5/8		
	3, 6	10-93	3/4 - 2 5/8		
	4, 7	10-94	3/4 - 2 5/8		
	8	10-95	5/8 - 2 5/8		

Roll Supports New Britain

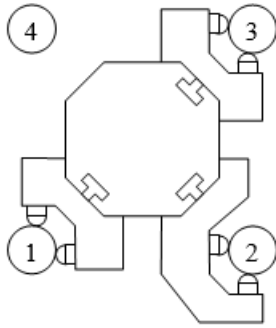

Models 40, 41

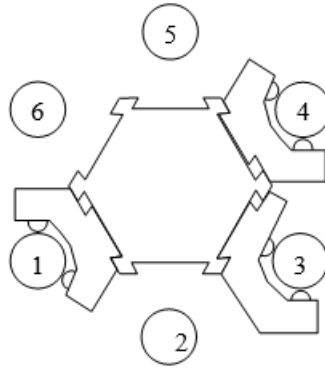

Models 60, 61

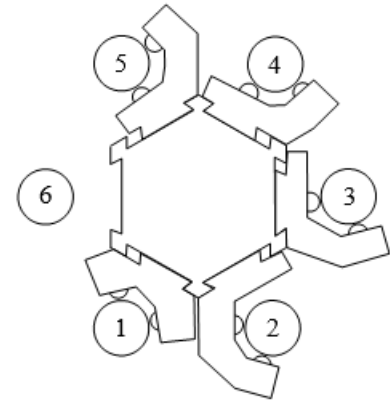

Models 52, 62

Machine	Position	Order #	Capacity	Roll Dia.
40 s/n ≥ 23847	1	10-100	5/16 - 1	5/8
	2	10-101		
	3	10-55	5/16 - 3/4	
41 s/n ≥ 23578	1, 3	10-141S	1/2 - 1 5/8	1 1/16
	2	10-142S		
51	1	10-40	3/16 - 1	5/8
	2	10-166		
	3, 5	10-41		
	4	10-165		
52	1	10-122	5/16 - 1 1/4	3/4
	2	10-123		
	3, 5	10-124		
	4	10-125		
60 s/n ≥ 24472	1, 4	10-40	3/16 - 1	5/8
	3	10-41		
61 s/n ≥ 24341	1, 4	10-32	1/4 - 2 1/8	15/16
	3	10-33		
62	1	10-115	3/8 - 2 1/16	15/16
	2	10-116		
	4	10-118		
	3, 5	10-117		
601	1 - 5	10-46	13/32 - 1 1/4	7/8
602	1 - 5	10-144	7/16 - 2 1/4	15/16

Roll Supports Wickman

Spindles	Machine	Position	Capacity	Order #	Spare Parts		
					Roll Holder	Roll	Pin
5	1 3/4	1	1/4 - 2	10-162	82-117	82-16-1	82-71-2
	2 1/4	2, 3, 4	1/4 - 1	10-38	82-7	82-2-1	82-2-2
6	1	1	3/16 - 1	10-201	82-36	82-2-1	82-2-2
			1/8 - 3/4	10-201A	82-29	82-9-1	82-9-2
		2, 3	3/16 - 1	10-202	82-36	82-2-1	82-2-2
			1/8 - 3/4	10-202A	82-29	82-9-1	82-9-2
		4	3/16 - 1	10-203	82-36	82-2-1	82-2-2
			1/8 - 3/4	10-203A	82-29	82-9-1	82-9-2
	1 3/8 1 3/4	1, 6	1/4 - 1 1/4	10-107	82-117	82-16-1	82-71-2
			1/8 - 15/16	10-107A	82-104	82-4-1	82-10-2
		2, 3	1/4 - 1 1/4	10-108	82-117	82-16-1	82-71-2
			1/8 - 15/16	10-108A	82-104	82-4-1	82-10-2
		4, 5	1/4 - 1 1/4	10-109	82-117	82-16-1	82-71-2
			1/8 - 1/2	10-109A	82-104	82-4-1	82-10-2
	2 1/4	1	1/2 - 2	10-34R	82-23	82-3-1	82-23-2
			1/4 - 1	10-34RA	82-101	82-55-1	82-101-2
		2	1/2 - 2	10-37R	82-23	82-3-1	82-23-2
			1/4 - 1	10-37RA	82-101	82-55-1	82-101-2
		3, 5	1/4 - 2	10-36R	82-23	82-3-1	82-23-2
		4	1/2 - 2	10-35R	82-23	82-3-1	82-23-2
	1/4 - 1		10-35RA	82-101	82-55-1	82-101-2	
	2 5/8 3 1/4	1, 6	1 - 3 1/4	10-209	82-45	82-3-1	82-23-2
2, 3		1 - 3 1/4	10-210				
8	1 3/4	1	1/4 - 1 3/4	10-200	82-45	82-3-1	82-23-2
		2		10-196			
		3, 6		10-199			
		4, 7		10-198			
		5, 8		10-197			

3 Styles for All your needs...

- Hardened, match-ground bearing surfaces for precise movement and extreme rigidity.
- Quick-change tool mechanism; Fast, easy setup.

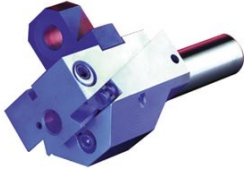

*Shank Style Recess Holder:
Economy, Flexibility, Ease of Use*



*Adj Stationary Recess Holders:
Robust, Rigid*



*Recess Milling Attachment:
Superior Performance, No Chip Problems*

<p>Shank style recess attachments</p> <p>Ideal for light undercuts and single O-rings. Its universal design allows it to be mounted on the widest variety of machines.</p>	<p>Adj Stationary recess attachments</p> <p>Designed for superior cutting and profiling capability as well as increased accuracy over shank style attachments. This model bolts directly to your machine's main tool slide. Its wide base provides more rigidity than shank style holders. Clamp style recess attachments offer superior accuracy, repeatability, and tool life.</p>	<p>Recess milling attachments outperform all other styles.</p> <p>Its true milling cutter eliminates taper from tool deflection, performs complex profiling and takes the kind of heavy undercuts normally associated with secondary work. The rotating tool produces fine chips which are easily washed from the cutting area with TRUE High Pressure through-tool coolant. Recess milling attachments also provide a much finer finish than can be achieved with either a shank or clamp style holder. You'll get faster setup, longer tool life, shorter tool changes and easier control of part quality. BME recess milling attachments feature Erikson style ER spindles for minimal runout and quick tool change.</p>
---	---	--

Features	Shank	Adj Stationary	Recess Milling
Universal mounting	X	X	X
Hardened & ground	X	X	X
Quick change tool mechanism	X	X	X
Fast, easy setup	X	X	X
Long service life	X	X	X
Light undercuts	X	X	X
Medium undercuts, profiling		X	X
Through tool coolant		X	X
Comes Standard w/ Draw Bar		X	X
Heavy cuts, complex profiling			X
Active control of tool deflection			X
Positive chip control			X
Fine infeed adjustments			X

Recess Tool Holders, Shank Style

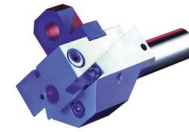

	58-10	58-12	58-1	58-2	58-3	58-7
Shank Diameter	3/4	1	1 ¼	1 ½	2	2 ½
Tool Bore	3/8	1/2	5/8	1	1 ¼	1 ¼
Bore Depth	3/4	3/4	7/8	1 ¼	1 ½	1 ½
Tool Offset	0.031	0.031	0.031	0.062	0.062	0.125
Degree Rise	16°	16°	15°	20°	18°	12°
Rise per .001 feed	0.00029	0.00029	0.00027	0.00036	0.00032	0.00021
Max. Expansion	0.179	0.179	0.201	0.273	0.274	0.213
Draw Bar	59-7	59-3	59-1	59-1	59-1	59-1
Stop Rod	59-53	59-50	59-51	59-51	59-51	59-51

New Britain Recommended Shank Style Recesses			
Machine Model	Order #	Draw Bar #	Stop Rod #
52	58-1	59-1	59-51
60	58-12	59-3	59-50
	58-1	59-1	59-51
61, 62	58-2	59-1	59-51
	58-3	59-1	59-51

National Acme Recommended Shank Style Recesses			
Machine Model	Order #	Draw Bar #	Stop Rod #
3/4"RA8, 1"RA6 9/16"RA6 1"RAN6	58-2	59-1	59-51
1 1/4"RA6 1 1/4"RB8 1 5/8"RBN8 1 5/8"RB8 1 5/8"RB6 2"RB6 2RB8	58-3	59-1	59-51
2 5/8"RB6 2 5/8"RB8 (Requires Bushing)	58-3	59-1	59-51

Wickman Recommended Shank Style Recesses			
Machine Model	Order #	Draw Bar #	Stop Rod #
5/8, 1	58-12	59-3	59-50
1 3/8, 1 3/4, 2 1/4	58-1	59-1	59-51
	58-2	59-1	59-51
2 5/8	58-2	59-1	59-51
3 1/4	58-3	59-1	59-51
	58-7	59-1	59-51

Davenport Recommended Shank Style Recess For use in 3rd, 4th and 5th pos (5th pos requires adapter bracket #14060 for draw bar)						
Order #	Draw Bar	Max. DOC	Travel	Shank	Tool Bore	Tool Offset
58-8	59-6	.161	9/16	3/4	3/8 x 3/4	.031

Adjustable Stationary and Recess Milling attachments

National Acme Machines				
Machine	Adj Stat Part #	Recess Milling Part #	Collet Size	Degree Rise
5/8 RN-6 (Flat base)	AA-10-19-0	AM-3-19-40-HP		10°
9/16 & 1" RA-6 & RAN-6 (Flat Base)	AA-10-1-0	AM-3-1-40-HP	ER25	10°
9/16 & 1" RA-6 & RAN-6 (Angular Base)	AA-10-2-0	AM-3-2-40-HP	ER25	10°
2 3/8 -HSC-6 Acme Chucker	AA-10-16-0	AM-3-18-59-HP	ER25	10°
1 1/4" RA-6 (Flat Base)	AA-12-3-0	AM-28-3-5-HP	ER32	15°
1 1/4" RA-6 (Angular Base)	AA-12-4-0	AM-31-4-5-HP	ER32	15°
1 1/4" RB-8 1 5/8" RBN-8	AA-12-5-0	AM-28-5-5-HP	ER32	15°
1 5/8" RA-6 & 8 1 5/8" RB-6 & 8 2" RB 6 & 8 2" RAS-6	AA-12-6-0	AM-28-6-15-HP	ER32	15°
2 5/8" RB-6	AA-18-8-0	AM-12-8-18-HP	ER32	15°
2 5/8" RB-8	AA-18-10-0	AM-12-10-18-HP	ER32	15°
3 1/2" RB-6	AA-18-11-0	AM-13-9-66-HP	ER40	15°
3 1/2" RB-8				
4" RB-6	AA-18-12-0	AM-12-13-XX-HP	ER40	15°

New Britain Machines				
Machine	Adj Stat Part #	Recess Milling Part #	Collet Size	Deg rise
51	NA-10-10-0	NM-3-10-40-HP	ER25	10 deg
52	NA-12-2-0	NM-28-2-28-HP	ER32	15 deg
60	NA-10-1010	NM-3-10-XX-HP	ER25	15 deg
61,62,656, 657	NA-12-3-0	NM-28-3-XX-HP	ER32	15 deg
602	NA-12-4-0	NM-28-4-XX-HP	ER32	15 deg
16	NA-16-6-0	NM-12-6-XX-HP	ER32	15 deg
88	NA-18-7-0	NM-12-7-90-HP	ER32	15 deg
865	NA-18-6-0	NM-12-6-XX-HP	ER32	15 deg

XX = Specify Spline Size (see page xx)

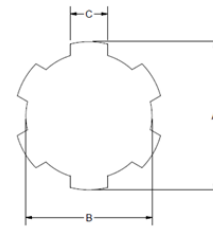

Wickman Machines				
Machine	Adj Stat Part #	Recess Milling Part #	Collet Size	Deg rise
1"-6 & 8	WA-10-20-0	WM-3-2-66-HP	ER25	10 deg
1 3/8" and 1 3/4"-6	WA-12-3-0	WM-28-3-47-HP	ER25	15 deg
1 3/4"-8 2 1/4"-6 6 5/8"-6 Chuck	WA-12-5-0	WM-28-5-47-HP	ER32	15 deg

Draw bar included on recess milling attachments. Erickson style spindle standard. Straight bores available on request. To add precision spindle bearings to recess milling attachment, Add **-P** to the end of part #

Why an Erickson style spindle?

- Flexibility- use the widest possible size of tooling.
- Better concentricity- the shank will automatically center itself with the spindle resulting in better finishes and more consistent geometry.

SPLINE NO.	SPLINE PART NO.	A	B	C	# TEETH	U-JOINT PART NO.
4	GRH-4-19	1.121	0.881	0.171	10	ARH-5-18
5	ARH-5-19	0.995	0.845	0.25	6	ARH-5-18
13	CRH-13-19	1.498	1.194	0.372	6	CRH-13-18
14	ARH-14-19	1.495	1.267	0.372	6	CRH-13-18
15	ARH-15-19	1.245	1.062	0.31	6	ARH-5-18
18	ARH-18-19	1.248	1.062	0.31	6	CRH-13-18
19	CRH-19-19	1.245	0.989	0.308	6	ARH-5-18
28	NRH-28-19	1.245	0.989	0.308	6	ARH-5-18
32	CRH-32-19	1.998	1.562	0.498	6	CRH-13-18
40	ARH-40-19	0.882	0.693	0.216	6	SRS-24-18
47	WRH-47-19	0.998	0.84	0.181	6	ARH-5-18
51	CRH-51-19	1.245	0.989	0.308	6	ARH-5-18
55	SRH-55-19	0.999	0.839	0.239	6	ARH-15-18
59	ARH-59-19	0.745	0.597	0.185	6	ARH-40-18
66	ARH-66-19	1.245	1.061	0.31	6	CRH-13-18
86	WRH-86-19	0.745	0.65	0.18	6	ARH-40-18
90	NRH-90-19	1.495	1.189	0.37	6	CRH-13-18

Rotary Recess Push Type Davenport

- Push Type Rotary Recess
- ER Collet Mounting System
- Allows for High Pressure Coolant thru the spindle
- Mounts in 3rd or 4th Pos
- 75% and 125% Ratios Available
- Special Ratios Available Upon Request
- High Precision Spindle Bearing Setup



Davenport Push Type Rotary Recess					
Pos	Ratio	Max DOC	ER Collet Size	Order #	
3rd	75	.25"	ER11	DV-660-003-75	
3rd	125	.25"	ER11	DV-660-003-125	
4th	75	.25"	ER11	DV-660-004-75	
	125	.25"	ER11	DV-660-004-125	



Stationary Push Type Recess



R - 6000 - 002

Machine Size

B - 9/16"RA-6 Acme
 D - 1"RA-6 Acme
 F - 1 1/4" RA-6 Acme
 I - 1 5/8"RB-6 Acme
 L - 2 5/8"RB-6 Acme
 P - 3/4"RA-8 Acme
 R - 1 1/4"RB-8 Acme
 V - 1 5/8"RBN-8 Acme
 S - 1 5/8"RB-8 Acme
 T - 2"RB-8 Acme
 U - 2 5/8"RB-8 Acme
 W158 - 5/8"-6 Wickman
 W1138 - 1 3/8"-6 Wickman
 W1134 - 1 3/4"-6 Wickman
 W11 - 1"-8 Wickman
 NB51 - Model 51 New Britain
 NB52 - Model 52 New Britain
 NB62 - Model 62 New Britain
 NB812 - Model 812 New Britain
 DV - Davenport

Position*

002
 003
 004
 005
 006
 007

Attachment Type

6500—Stationary Push Type Recess

Visit us Online at www.bmeattachments.com
 3763 Lapeer Rd, Suite E— Port Huron, MI 48060
 Office 810-937-2974 / Fax 810-937-2975

A Passion for Precision...

A bold new design in precision shaving systems for shops looking for a competitive edge.

Uses most of the same components as our original, pin-style shave tool holders.

Designed with the fewest possible number of parts for easy maintenance and reliable operation.

Use traditional dovetail tooling or our more advanced Direct Mount™ Insert style tooling. Inserts improve performance and productivity.

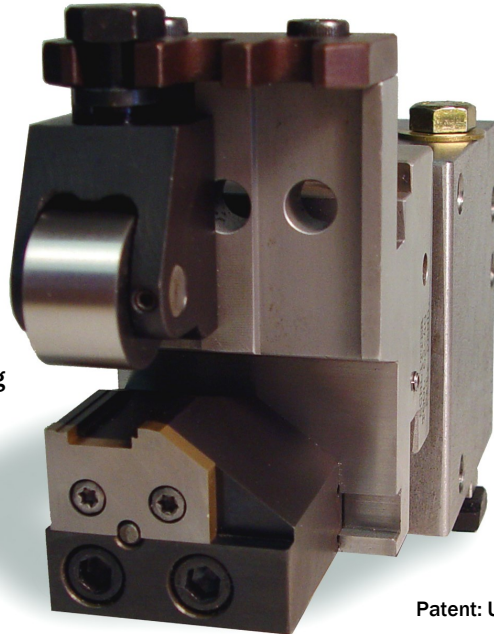

Precision gib system provides precise fit even after years of operation.

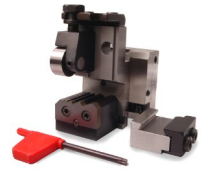

19 different holders, and counting, for all makes and sizes of screw machine.

Patent: US 6,880,436 B2

From the original manufacture of the most widely used shave tool holder in the world.



We spent years getting feedback from owners and operators before putting pen to paper to design our advanced new shaving system. The main drawback to our original, best-selling pin style shave tool holders was a slide mechanism that could wear over time, requiring regular maintenance to prevent a loose head which might allow chatter.

Our New G-Series shaving system resists wear in the slide mechanism by increasing the hardness and area of the bearing surface. The tapered gib allows for quick adjustment for wear when it occurs. The robust design is engineered with the fewest possible number of parts to reduce maintenance and to provide consistent accuracy over time.

We designed the new holder to accept both traditional dovetail tooling and advanced new insert style tooling.

We call this our Direct Mount™ insert system. This system eliminates the design limitations of using dovetail adapters with inserts. We eliminated tool clamps for most parts under 1 ½" long for better coolant and chip flow and to avoid any pockets where a small chip could cock the insert during tool change.

Direct Mount™ inserts are self-aligning and essentially fool proof. They are available in HSS and a tough, micrograin carbide in both unfinished blanks and with finished forms. Because inserts can be positioned anywhere, one insert blank can replace several dovetail blanks with various offsets.

Tool posts are extremely rigid. One customer reported shaving over 1/2" from the diameter on 1000 pieces when an improperly clamped form tool backed off the part. The parts were perfectly to size and the holder was completely undamaged. They only noticed a problem from a slight heat blemish on the part from the aggressive cut.

The G-Series holders are a great value and preserve your investment in parts, mounting blocks and tooling. The next time you need a shave tool holder, make it a G-Series holder from Schlitter Tool.

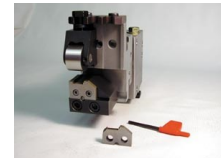
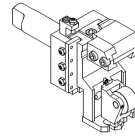
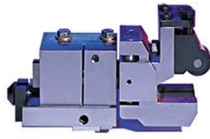

Schlitter Pin and G Type Heads

Traditional pin-style shave tool holder shown with optional adjustable shave block.

Model B are Box Type Shank Shaves that have adjustable spring tension

New G-Series™ Shaving System shown with optional Direct Mount™ tool post and insert.

Holder Capacity	Dovetail Size	Max. Tool Length	Shank Diameter	Original Pin Style	Body Length	Model "B" Type	NEW G-series	Body Length
0 to 1/2	1/2	1 1/8	7/8	62-1H	2 1/8	121-79	n/a	2 1/8
0 to 5/8	5/8	1 1/4	1	62-2	2 3/8	29-2	62-2G	2 5/8
0 to 1	5/8	1 1/2	1 1/4	62-62H	3	36-62H	62-62G	3 1/4
0 to 1	1	1 5/8	1 1/4	62-4H	3 1/8	36-4H	62-4G	3 3/8
0 to 1 1/4	1	1 3/4	1 1/4	62-5	3 1/2	51-5	62-5G	3 3/4
3/8 to 1 5/8	1	1 3/4	1 1/2	62-6	3 1/2	48-6	62-6G	3 3/4
1 3/4 to 2	1 1/4	1 3/4	1 1/2	62-7	3 1/2	49-7	62-7G	3 3/4
1 1/4 to 2 1/4	1 1/4	1 3/4	1 1/2	62-8	3 1/2	75-7	62-8G	3 3/4
1 1/4 to 2 5/8	1 1/2	1 7/8	1 1/2	62-9	3 3/4	47-9	62-9G	3 3/4
1 1/2 to 3	1 1/2	1 7/8	1 3/4	62-10	4			
1 5/8 to 3 1/2	1 1/2	1 7/8	1 3/4	62-11	4	40-11		
2 1/8 to 4	1 5/8	2 1/16	2	62-12H	4 3/8			

Mount Blocks for Shank Style Shave heads, Six Spindle Nat'l Acme

Machine Model	Shave Order #	Shaving Capacity	Dovetail Size	Block for Pos. 2 dd	Block for Pos. 3	Block for Pos. 4	Shank Size/Block Bore
7/16 RA	62-1H	0 - 1/2	1/2	71-302H	71-302H	71-302H	7/8
3/16 R, RA, RAN 1 RA, RAN	62-1H	0 - 1/2	1/2	71-167H	71-112H	71-112H	7/8
	62-2, 62-2G	0 - 5/8	5/8	71-45	71-43	71-57	1
	62-62H	0 - 1	5/8	71-38	71-41H	71-41H	1 1/4
	62-4H	0 - 1	1	71-38	71-41H	71-41H	1 1/4
5/8 RN	62-2, 62-2G	0 - 5/8	5/8	71-57	71-43	71-57	1
	62-62H, 62-62G	0 - 1	5/8	71-41H	71-41H	71-41H	1 1/4
	62-4H, 62-4G	0 - 1	1	71-41H	71-41H	71-41H	1 1/4
1 R, RAS 1 1/4 R, RA, RB	62-2, 62-2G	0 - 5/8	5/8	71-133	71-204	71-133	1
	62-62H, 62-62G	0 - 1	5/8	71-64	71-36	71-64	1 1/4
	62-4H, 62-4G	0 - 1	1	71-64	71-36	71-64	1 1/4
	62-5, 62-5G	0 - 1 1/4	1	71-64	71-36	71-64	1 1/4
1 3/8, 1 5/8 AG	62-4H, 62-4G	0 - 1	1	61-94	61-94	61-94	1 1/4
	62-5, 62-5G	0 - 1 1/4	1	61-95	61-96	61-95	1 1/4
	62-6, 62-6G	3/8 - 1 5/8	1	61-95	61-96	61-95	1 1/2
1 5/8 R, RA, RB 2 RB, RAS	62-4H, 62-4G	0 - 1	1	71-136	71-127	71-67	1 1/4
	62-5, 62-5G	0 - 1 1/4	1	71-136	71-127	71-67	1 1/4
	62-6, 62-6G	3/8 - 1 5/8	1	71-40	71-32	71-39	1 1/2
	62-7, 62-7G	3/4 - 2	1 1/4	71-40	71-32	71-39	1 1/2
2, 2 1/4, 2 5/8 R, RA	62-6, 62-6G	3/8 - 1 5/8	1	71-105	71-32	71-39	1 1/2
	62-7, 62-7G	3/4 - 2	1 1/4	71-105	71-32	71-39	1 1/2
	62-8, 62-8G	1 - 2 1/4	1 1/2	71-105	71-32	71-39	1 1/2
	62-9, 62-9G	1 1/4 - 2 5/8	1 1/2	71-105	71-32	71-39	1 1/2

Continued next page

Mount Blocks for Shank Style Shave heads, Six Spindle Acme Continued

Machine Model	Shave Order #	Shaving Capacity	Dovetail Size	Block for Pos. 2 dd	Block for Pos. 3	Block for Pos. 4	Shank Size/Block Bore
2 5/8 RB	62-6, 62-6G	3/8 - 1 5/8	1	71-105	71-62	71-63	1 1/2
	62-7, 62-7G	3/4 - 2	1 1/4	71-105	71-62	71-63	1 1/2
	62-8, 62-8G	1 - 2 1/4	1 1/2	71-105	71-62	71-63	1 1/2
	62-9, 62-9G	1 1/4 - 2 5/8	1 1/2	71-105	71-62	71-63	1 1/2
3, 3 1/2 RA, RB 4 RB	62-6, 62-6G	3/8 - 1 5/8	1	71-63	71-62	71-63	1 1/2
	62-7, 62-7G	3/4 - 2	1 1/4	71-63	71-62	71-63	1 1/2
	62-8, 62-8G	1 - 2 1/4	1 1/2	71-63	71-62	71-63	1 1/2
	62-9, 62-9G	1 1/4 - 2 5/8	1 1/2	71-63	71-62	71-63	1 1/2
	62-10	1 1/2 - 3	1 1/2	71-48	71-83	71-48	1 3/4
	62-11	1 5/8 - 3 1/2	1 1/2	71-48	71-83	71-48	1 3/4
	62-12H	2 1/8-4	1 5/8	71-114	71-115	71-114	2

Mount Blocks for Shank Style Shave heads, Eight Spindle Nat'l Acme

Machine Model	Shave Holder Order #	Shaving Capacity	Dovetail Size	Pos. 2 dd	Pos. 3	Pos. 4	Pos. 5
3/4 RA	62-1H	0 - 1/2	1/2	71-167H	72-112H	71-112H	71-112H
	62-2, 62-2G	0 - 5/8	5/8	71-45	71-43	71-43	71-43
	62-62H, 62-62G (5 th only)	0 - 1	5/8	71-38	71-41H	71-41H	71-41H
	62-4H	0 - 1	1	71-38	71-41H	71-41H	71-41H
1 1/4 RB 1 5/8 RBN	62-2, 62-2G	0 - 5/8	5/8	71-133	71-204	71-204	71-133
	62-62H, 62-62G	0 - 1	5/8	71-64	71-64	71-36	71-64
	62-4H, 62-4G	0 - 1	1	71-64	71-64	71-36	71-64
	62-5, 62-5G	0 - 1 1/4	1	71-64	71-64	71-36	71-64
	62-6, 62-6G	3/8 - 1 5/8	1	71-46	71-46	71-34	71-46
1 5/8 RA, RB 2 RB	62-4H, 62-4G	0 - 1	1	71-136	71-64	71-169	71-136
	62-5, 62-5G	0 - 1 1/4	1	71-136	71-64	71-169	71-136
	62-6, 62-6G	3/8 - 1 5/8	1	71-40	71-46	71-60	71-40
	62-7, 62-7G	3/4 - 2	1 1/4	71-40	71-46	71-60	71-40
2 1/4, 2 5/8 RA, RB	62-5, 62-5G	0 - 1 1/4	1	71-347	71-67	71-127	71-67
	62-6, 62-6G	3/8 - 1 5/8	1	71-63	71-39	71-32	71-39
	62-7, 62-7G	3/4 - 2	1 1/4	71-63	71-39	71-32	71-39
	62-8, 62-8G	1 - 2 1/4	1 1/2	71-63	71-39	71-32	71-39
	62-9	1 1/4 - 2 5/8	1 1/2	71-63	71-39	71-32	71-39
3 1/2, 4 RB	62-7, 62-7G	3/4 - 2	1 1/4	71-63	71-63	71-62	71-63
	62-8, 62-8G	1 - 2 1/4	1 1/2	71-63	71-63	71-62	71-63
	62-9	1 1/4 - 2 5/8	1 1/2	71-63	71-63	71-62	71-63
	62-10	1 1/2 - 3	1 1/2	71-48	71-48	71-83	71-48
	62-11	1 5/8 - 3 1/2	1 1/2	71-48	71-48	71-83	71-48
	62-12H	2 1/8-4	1 5/8	71-114	71-114	71-115	71-114

Mount Blocks for Shank Style Shave heads (Pin Type), New Britain

Machine Model	Shaving Capacity	Dovetail Size	Pin Style Shave Holder	Mounting Blocks				
				Pos. 1	Pos. 2	Pos. 3	Pos. 4	Pos. 5
51 (1 cap.) 52 (1¼ cap.)	0 - 5/8	5/8	62-2	61-4	61-3	61-3†	61-4	61-3
	0 - 1	5/8	62-62H	61-6	61-5	61-5†	61-6	61-5
	0 - 1	1	62-4	61-6	61-5	61-5†	61-6	61-5
	0 - 1 ¼	1	62-5	61-6	61-5	61-5†	61-6	61-5
60 (1 cap.) s/n ≥ 24472	0 - 5/8	5/8	62-2	61-4		61-3	61-4	
	0 - 1	5/8	62-62H	61-6‡		61-5*	61-6‡	
	0 - 1	1	62-4	61-6‡		61-5*	61-6‡	
	0 - 1 ¼	1	62-5	61-6‡		61-5*	61-6‡	
61 s/n ≥ 24341 656 (1⅝ and 2¼ cap.)	0 - 5/8	5/8	62-2	61-33		61-34	61-33	
	0 - 1	5/8	62-62H	61-21		61-22	61-21	
	0 - 1	1	62-4	61-21		61-22	61-21	
	0 - 1 ¼	1	62-5	61-21		61-22	61-21	
	3/8 - 1 ⅝	1	62-6	61-8		61-7	61-8	
	3/4 - 2	1 ¼	62-7	61-8		61-7	61-8	
	1 - 2 ¼	1 ½	62-8	61-8		61-7	61-8	
62 657, 812, 816, 817 (2¼ cap.)	0 - ⅝	5/8	62-2	61-33	61-34	61-34†	61-33	61-34
	0 - 1	5/8	62-62H	61-21	61-22	61-22†	61-21	61-22
	0 - 1	1	62-4H	61-21	61-22	61-22†	61-21	61-22
	0 - 1 ¼	1	62-5	61-21	61-22	61-22†	61-21	61-22
	3/8 - 1 ⅝	1	62-6	61-8	61-7	61-7†	61-8	61-7
	3/4 - 2	1 ¼	62-7	61-8	61-7	61-7†	61-8	61-7
	1 - 2 ¼	1 ½	62-8	61-8	61-7	61-7†	61-8	61-7
601 & 602 2¼ cap.	0 - 1/2	1/2	62-1H	61-37H	61-27H	61-37H	61-27H	61-37H**
	0 - 5/8	5/8	62-2	61-10	61-13	61-10	61-13	61-10**
	0 - 1	5/8	62-62H	61-11	61-12	61-12	61-11	61-12**
	0 - 1	1	62-4	61-11	61-12	61-12	61-11	61-12**
	0 - 1 ¼	1	62-5	61-11	61-12	61-12	61-11	61-12**
	3/8 - 1 ⅝	1	62-6	61-1	61-2	61-2	61-1	61-2**
	3/4 - 2	1 ¼	62-7	61-1	61-2	61-2	61-1	61-2**
	1 - 2 ¼	1 ½	62-8	61-1	61-2	61-2	61-1	61-2**

† must have 3rd position shelf type slide. ‡ remove 5/8 x 1 section of cross slide for clearance per layout #12388 to clear assembly.

* capacity limited to ½" in this position to clear roll holder.

** 5th position slide must have T-slots and slide dimensions identical to 1st & 3rd position slides.

Mount Blocks for Shank Style Shave heads (G Type), New Britain

Machine Model	Shaving Capacity	Dovetail Size	Advanced G-Series	Mounting Blocks				
				Pos. 1	Pos. 2	Pos. 3	Pos. 4	Pos. 5
51 (1 cap.) 52 (1¼ cap.)	0 - 5/8	5/8	62-2G	61-4G	61-3G	61-3G†	61-4G	61-3G
	0 - 1	5/8	62-62G	61-6	61-5	61-5†	61-6	61-5
	0 - 1	1	62-4G	61-6	61-5	61-5†	61-6	61-5
	0 - 1 ¼	1	62-5GU	61-6	61-5	61-5†	61-6	61-5
60 (1 cap.) s/n ≥ 24472	0 - 5/8	5/8	62-2G	61-4		61-3	61-4	
	0 - 1	5/8	62-62G	61-6‡		61-5*	61-6‡	
	0 - 1	1	62-4G	61-6‡		61-5*	61-6‡	
	0 - 1 ¼	1	62-5GU	61-6‡		61-5*	61-6‡	
61 s/n ≥ 24341 656 (1½ and 2¼ cap.)	0 - 5/8	5/8	62-2G	61-33G		61-34G	61-33G	
	0 - 1	5/8	62-62G	61-21		61-22	61-21	
	0 - 1	1	62-4G	61-21		61-22	61-21	
	0 - 1 ¼	1	62-5GU	61-21		61-22	61-21	
	3/8 - 1 ⅝	1	62-6G	61-8G		61-7G	61-8G	
	3/4 - 2	1 ¼	62-7G	61-8G		61-7G	61-8G	
	1 - 2 ¼	1 ½	62-8G	61-8G		61-7G	61-8G	
62 657, 812, 816, 817 (2¼ cap.)	0 - 5/8	5/8	62-2G	61-33G	61-34G	61-34G†	61-33G	61-34G
	0 - 1	5/8	62-62G	61-21	61-22	61-22†	61-21	61-22
	0 - 1	1	62-4G	61-21	61-22	61-22†	61-21	61-22
	0 - 1 ¼	1	62-5GU	61-21	61-22	61-22†	61-21	61-22
	3/8 - 1 ⅝	1	62-6G	61-8G	61-7G	61-7G†	61-8G	61-7G
	3/4 - 2	1 ¼	62-7G	61-8G	61-7G	61-7G†	61-8G	61-7G
	1 - 2 ¼	1 ½	62-8G	61-8G	61-7G	61-7G†	61-8G	61-7G
601 & 602 2¼ cap.	0 - 5/8	5/8	62-2G	61-10	61-13	61-10	61-13	61-10**
	0 - 1	5/8	62-62G	61-11	61-12	61-12	61-11	61-12**
	0 - 1	1	62-4G	61-11	61-12	61-12	61-11	61-12**
	0 - 1 ¼	1	62-5GU	61-11	61-12	61-12	61-11	61-12**
	3/8 - 1 ⅝	1	62-6G	61-1	61-2	61-2	61-1	61-2**
	3/4 - 2	1 ¼	62-7G	61-1	61-2	61-2	61-1	61-2**
	1 - 2 ¼	1 ½	62-8G	61-1	61-2	61-2	61-1	61-2**

† must have 3rd position shelf type slide. ‡ remove 5/8 x 1 section of cross slide for clearance per layout #12388 to clear assembly.

* capacity limited to ½" in this position to clear roll holder.

** 5th position slide must have T-slots and slide dimensions identical to 1st & 3rd position slides.

Mount Blocks for Shank Style Shave heads, Wickmans

# Spindles	Machine Model	Pin Style Shave	G-Series Shave	Shaving Capacity	Dovetail Size	Mounting Blocks x Position						
						2	3	4				
4	3 ½	62-11		1 ⅝ to 3 ½	1 ½	71-83†	71-48‡	71-83‡				
5	1 ⅜	62-62H		0 - 1	5/8	71-217	71-218	71-217				
		62-4H		0 - 1	1							
		62-5		0 to 1 ¼	1				71-215	71-216	71-215	
	1 ¾ 2 ¼	62-2	62-2G		0 - 5/8	5/8	71-428	71-429	71-428			
		62-62H	62-62G		0 - 1	5/8						
		62-4H	62-4G		0 - 1	1						
		62-5	62-5G		0 to 1 ¼	1				71-306	71-307	71-306
		62-6	62-6G		3/8 to 1 ⅝	1						
62-7	62-7G		1 ¾ to 2	1 ¼								

†3 ½ travel required to clear 3 ½ capacity stock at index.

‡2 ½ travel required to clear 3 ½ stock at index.

# Spindles	Machine Model	Pin Style Shave	G-Series Shave	Shaving Capacity	Dovetail Size	Mounting Blocks by Position				
						1	2	3	4	5
6	1, 6-26	62-1H	62-1G	0 - 1/2	1/2		71-526	71-526		71-526
		62-2	62-2G	0 - 5/8	5/8	71-41H	71-423	71-423	71-471	71-423
		62-62H	62-62G	0 - 1	5/8		71-309	71-309	71-308	71-309
		62-4H	62-4G	0 - 1	1		71-309	71-309	71-308	71-309
	1 ⅜, 1 ¾	62-4H	62-4G	0 to 1	1	71-429	71-428	71-429	71-429	71-428
		62-5	62-5G	0 to 1 ¼	1					
		62-6	62-6G	3/8 to 1 ⅝	1	71-307	71-306	71-307	71-307	71-306
	2, 2 ¼	62-7	62-7G	3/4 - 2	1 ¼					
		62-4H	62-4G	0 to 1	1	71-136	71-169		71-136	71-169
		62-5	62-5G	0 to 1 ¼	1					
		62-6	62-6G	3/8 - 1 ⅝	1	71-40	71-60		71-40	71-60
	2 ⅝, 3 ¼	62-7	62-7G	3/4 - 2	1 ¼					
		62-8	62-8G	1 - 2 ¼	1 ½					
		62-6	62-6G	3/8 - 1 ⅝	1	71-63	71-62	71-62	71-63	71-62
		62-7	62-7G	3/4 - 2	1 ¼					
		62-8	62-8G	1 - 2 ¼	1 ½					
62-9	62-9G	1 ¼ - 2 ⅝	1 ½							
62-10	62-10G	1 ½ - 3	1 ½	71-48	71-83	71-83	71-48	71-83		
62-11	62-11G	1 ⅝ - 3 ½	1 ½							

# Spindles	Machine Model	Pin Style Shave	G-Series Shave	Shaving Capacity	Dovetail Size	Mounting blocks by position							
						2	3	4	5	6	7	8	
8	1	62-2	62-2G	0 - 5/8	5/8	71-522	71-535	71-513	71-524	71-522	71-535	71-513	
		62-4H	62-4G	0 - 1	1		71-512				71-512		
	1 ¾	62-6	62-6G	3/8 - 1 ⅝	1	71-60			71-40	71-60			

Model "B" Box Way Type Shave Holders



FASTER SETUP - All adjustments simple and conveniently to operator

QUICK ELIMINATION OF TAPER - Adjusting screws in hear are located off-center and close to shave tool

POSITIVE CHATTER CONTROL - Both gib and spring float adjustments are easily accessible

ADJUSTABLE BASE - Base permits use on machines which do not have slide adjustment

UNIVERSAL USAGE OF BASE - Simple reversing of head permits using the same base for all normal shaving positions

NO FLEXING OR LOSS OF ACCURACY - Heavy Duty head is made of 6150 steel, heat treated, and ground

SIMPLE TO RECONDITION - Can be reconditioned by using only a surface grinder

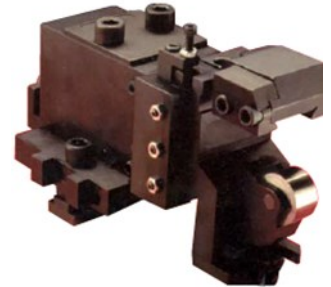

IMPORTANT - HOLDER NO. CODE					
MACHINE	SHAVE	HEAD	ROLL	MOUNT	BASE
A	S	-29	-1	-41	-68

If different roll rest is need L.H., R.H., or Wide add the letter after the roll no.

AS-29-1RH-41-68

Example: AS-29-1LH-41-68

AS-29-1W-41-68

Head Code No.	29	36	51	48	49	75	47	40
Max Capacity	5/8"	1"	1 1/4"	1 5/8"	2"	2 1/4"	2 5/8"	3 1/2"
Min. Capacity	-0-	-0-	-0-	3/8"	3/4"	1"	1 1/4"	1 5/8"
Dovetail Size	5/8"	1"	1"	1"	1 1/4"	1 1/4"	1 1/2"	1 1/2"
A	0.81	1.00	1.12	1.31	1.50	1.62	1.81	2.25
B	1.31	1.68	1.75	1.75	1.81	1.81	1.88	1.94
C	0.914	1.289	1.289	1.289	1.557	1.557	1.789	1.789
D	0.36	0.53	0.53	0.53	0.53	0.53	0.41	0.41
E	0.25	0.34	0.34	0.34	0.42	0.42	0.42	0.42
F	0.75	1.25	1.25	1.25	1.25	1.25	1.25	1.25
G	0.31	0.37	0.37	0.37	0.50	0.50	0.50	0.50
H	1.62	2.37	2.37	2.37	2.62	2.62	2.62	2.62
I	0.12	0.19	0.19	0.19	0.25	0.25	0.25	0.25
J	0.56	0.81	0.81	0.81	0.91	0.91	0.91	0.91
K	1.00	1.38	1.38	1.38	1.56	1.56	1.56	1.56
L	-0.06	-0.06	-0.06	-0.06	0.01	0.01	0.01	0.01
M	0.37	0.57	0.57	0.57	0.66	0.66	0.66	0.66
N	0.81	1.19	1.19	1.19	1.32	1.32	1.32	1.32
P	0.43	1.18	1.18	1.18	1.30	1.30	1.30	1.30
Q	0.88	1.81	1.81	1.81	1.96	1.96	1.96	1.96
R	1.31	2.43	2.43	2.43	2.62	2.62	2.62	2.62
S	3.38	4.43	5.06	5.25	5.68	5.93	6.44	7.37
ROLL REST CODE	No.1	No. 3	No. 3	No. 3	No. 5	No. 5	No. 5	No. 5

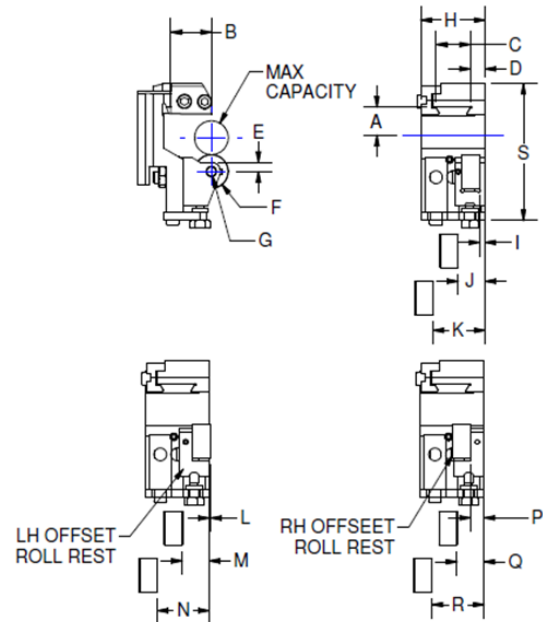

Model B Shave Head Assy

National Acme Machines - Model "B" Shaves			
Machine: Size & Model	Pos to be Used	Head Size and DT	Ordering Holder Code #
7/8"RA & 1"RA-4 5/8"RN-6, 9/16", 1"RA & RAN-6, 3/4"RA-8	2 & 3 2DD, 3 & 4	5/8" Capacity 5/8" DT	AS-29-1-41-68
7/8"RA & 1"RA-4 5/8"RN-6, 9/16", 1"RA & RAN-6, 3/4"RA-8	2 & 3 2DD, 3 & 4	1" Capacity 1" DT	AS-36-3-25-30
1 1/4"RA-6 1 1/4"RB-8	2DD, 3 & 4 2DD, 4 & 5	1 1/4" Capacity 1" DT	AS-51-3-33-42
1 3/8"AG-6	2DD, 3 & 4	1 1/4" Capacity 1" DT	AS-51-3-33-60
1 5/8", 2"RAS-4 1 5/8"RBN-8	2 & 3 2DD, 4 & 5	1 5/8" Capacity 1" DT	AS-48-3-33-42
1 5/8", 2"RB & RA-6 1 5/8", 2"RB-8	2DD, 3 & 4 2DD, 4 & 5	1 5/8" Capacity 1" DT	AS-48-3-33-39
2"RAS-6	2DD, 3 & 4	2" Capacity 1 1/4" DT	AS-49-5-33-43
2"RA-6	2DD, 3 & 4	2" Capacity 1 1/4" DT	AS-49-5-33-40
2"RB-6 2"RB-8	2DD, 3 & 4 2DD, 4 & 5	2" Capacity 1 1/4" DT	AS-49-5-33-39
2 5/8"RB-4 2 5/8"RB-6	2 & 3 2DD, 3 & 4	2 5/8" Capacity 1 1/2" DT	AS-47-5-32A-50
2 5/8"RA-6	2DD, 3 & 4	2 5/8" Capacity 1 1/2" DT	AS-47-5-32A-38A
2 5/8"RB-8	2DD, 4 & 5	2 5/8" Capacity 1 1/2" DT	AS-47-5-37A-69
3 1/2"RB-4 3 1/2"RA & RB-6 3 1/2" RB-8	2 & 3 2DD, 3 & 4 2DD, 4 & 5	3 1/2" Capacity 1 1/2" DT	AS-40-5-32A-50
4"RB-6	2DD, 3 & 4	4" Capacity 1 5/8" DT	AS-90-5-32A-50

New Britain Machines - Model "B" Shaves			
Machine: Size & Model	Pos to be Used	Head Size and DT	Ordering Holder Code #
51, 52	1,2,3,4,5	5/8" Capacity 5/8" DT	NS-29-1-41-51B
60	1,3,4		
51, 52	3,4,5	1" Capacity 1" DT	NS-36-3-53-71
60	1,4		
51, 52	1,2,3,4,5	1 1/4" Capacity 1" DT	NS-51-3-53-71
60	3,4		
61	1,3,4	1 1/4" Capacity 1" DT	NS-51-3-33-40
		1 5/8" Capacity 1" DT	NS-48-3-33-49
62	1,2,3,4,5	1 1/4" Capacity 1" DT	NS-51-3-33-49
		1 5/8" Capacity 1" DT	NS-48-3-33-49
		2" Capacity 1 1/4" DT	NS-49-5-33-49
625,627,635	1,2,3,4,5	2 5/8" Capacity 1 1/2" DT	NS-47-5-32-55B
		3 1/2" Capacity 1 1/24" DT	NS-40-5-32-55
812,816,817	1,4,5,6	1 5/8" Capacity 1" DT	NS-48-3-33-65
816,817	1,4,5,6	2" Capacity 1 1/4" DT	NS-49-5-33-65
82	4,5,6	2" Capacity 1 1/4" DT	



Visit us Online at www.bmeattachments.com
 3763 Lapeer Rd, Suite E— Port Huron, MI 48060
 Office 810-937-2974 / Fax 810-937-2975

Model B Shave Head Assy Continued

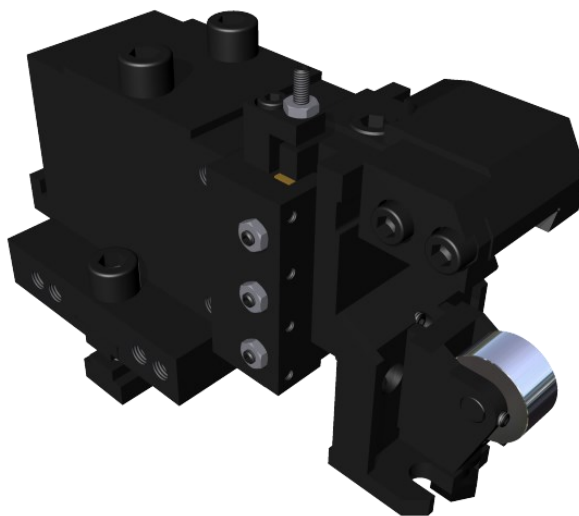
Wickman - Model "B" Shaves			
Machine: Size & Model	Pos to be Used	Head Size and DT	Ordering Holder Code #
1"-6	4,5	5/8" Capacity 5/8" DT	W-29-1-41-72
1"-8	5,6		
1"-6	4,5	1" Capacity 1" DT	W-36-25-25-51
1"-8	4,6		
1"-8	4,5	5/8" Capacity 5/8" DT	W-94-1W-41-83
		1" Capacity 1" DT	W-36A-3-25-83
1 3/8"-6, 1 3/4"-6	4,5	1 1/4" Capacity 1" DT	W-51-3-33-45
		1 5/8" Capacity 1" DT	W-48-3-33-45
2 1/4"-6	3,4,5	2 1/4" Capacity 1 1/4" DT	W-49-5-33-39



Davenport Shave Heads

Holder Style	Order #	Details	2 nd or B	3 rd or C	4 th or D	Notes
 New G-Series	62-72G	0-5/8 cap. 1/2 dovetail	71-229S2	71-313S	71-360	Adjustable dovetail slide resists chatter, improves accuracy.
	62-77G†	0-7/8 cap. 1/2 dovetail				Allows for traditional dovetail tool or Direct Mount™ Inserts.
 Pin Style	62-72	0-5/8 cap. 1/2 dovetail	71-229	71-313S	71-360	Traditional Pin Style holder is an economical choice for finishing diameters. Built-in taper adjustment.
	62-77†	0-7/8 cap. 1/2 dovetail				
 Model "B" Shank Style	111-87	0-5/8 cap. 1/2 dovetail	71-229	71-313S	71-360	Adjustable box way slide resists chatter, improves accuracy.
	95-87†	0-7/8 cap. 1/2 dovetail				

† For 7/8 Oversize Model Only. Note: G-Series Shaving System Shown with Optional Direct Mount™ Tool Post and Inserts

Tooling Options



Insert Style Tooling: For those looking to advance their shops in quality and productivity. Works best with G-Series Shaving Systems (the most advanced shave tool holder available today). Inserts are great time savers. They must be used with dovetail adapters or tool posts. Our insert system promotes better coolant and chip flow than the competition. We also have no minimum orders and can provide inserts in both carbide and HSS.

Better chip and coolant flow than the competition.

Adapters about 1/3 less cost than the competition.

Shave Supports

Tool Slide Mounted National Acme Six Spindle



	Machine Model	Style	Pos. 2	Pos. 3	Pos. 4	Roll Holder	Roll Width
Angular Tool Slide	9/16 R, RA 1 RA	Standard	85-26	85-3	85-4	82-50	3/8
		Wide	85-26A	85-3A	85-4A	82-57	3/4
		Tapered	85-26B	85-3B	85-4B	82-57	3/4
	1 R, RAS 1 ¼ R, RA	Standard	85-22	85-6	85-12	82-53	3/8
		Wide	85-22A	85-6A	85-12A	82-61	3/4
		Tapered	85-22B	85-6B	85-12B	82-61	3/4
2, 2 ¼, 2 ⅝ R, RA	Wide	85-87A	85-21A	85-48A	82-60	1	
	Tapered	85-87B	85-21B	85-48B	82-60	1	
Flat Tool Slide	7/16 RA	Standard	85-75	85-72	85-73	82-118	3/8
		Wide	85-75A	85-72A	85-73A	82-119	1/2
		Tapered	85-75B	85-72B	85-73B	82-119	1/2
	5/8 RN	Standard	85-109	85-109	85-109	82-50	3/8
		Wide	85-109A	85-109A	85-109A	82-57	3/4
		Tapered	85-109B	85-109B	85-109B	82-57	3/4
	9/16, 1 RAN	Standard	85-83	85-45	85-55	82-50	3/8
		Wide	85-83A	85-45A	85-55A	82-57	3/4
		Tapered	85-83B	85-45B	85-55B	82-57	3/4
	1 ¼ RA, RB	Standard	85-60	85-59	85-58	82-108	3/8
		Wide	85-60A	85-59A	85-58A	82-109	3/4
		Tapered	85-60B	85-59B	85-58B	82-109	3/4
	1 ⅝ RA, RB 2 RB, RAS	Standard	85-19	85-10	85-11	82-55	1/2
		Wide	85-19A	85-10A	85-11A	82-82	1
		Tapered	85-19B	85-10B	85-11B	82-82	1
	2 ⅝ RB	Wide	85-88A	85-76A	85-44A	82-116	1
		Tapered	85-88B	85-76B	85-44B	82-116	1
	3, 3 ½ RA, RB	Wide	85-42A	85-57A	85-89A	82-116	1
Tapered		85-42B	85-57B	85-89B	82-116	1	

Tool Slide Mounted National Acme Eight Spindle

Machine Model	Style	Pos. 2	Pos. 3	Pos. 4	Pos. 5	Pos. 6	Roll Width
3/4 RA	Standard	85-117		85-118	85-121		3/8
	Wide	85-117A		85-118A	85-121A		3/4
	Tapered	85-117B		85-118B	85-121B		3/4
1 ¼ RB 1 ⅝ RBN	Standard	85-99	85-100	85-96	85-101	85-102	1/2
	Wide	85-99A	85-100A	85-96A	85-101A	85-102A	1
	Tapered	85-99B	85-100B	85-96B	85-101B	85-102B	1
1 ⅝ RA, RB 2 RB	Standard	85-82	85-122	85-35	85-85	85-110	1/2
	Wide	85-82A	85-122A	85-35A	85-85A	85-110A	1
	Tapered	85-82B	85-122B	85-35B	85-85B	85-110B	1
2 ¼, 2 ⅝ RA, RB	Wide	85-78A	85-103A	85-84A	85-86A	85-103A	1
	Tapered	85-78B	85-103B	85-84B	85-86B	85-103B	1

Visit us Online at www.bmeattachments.com
 3763 Lapeer Rd, Suite E— Port Huron, MI 48060
 Office 810-937-2974 / Fax 810-937-2975

Tool Slide Mounted New Britain



Machine	Style	Pos. 1	Pos. 2	Pos. 3	Pos. 4	Pos. 5	Roll Width
41	Standard	85-1		85-1			3/8
	Wide	85-1A		85-1A			
	Tapered	85-1B		85-1B			
51	Standard	85-111	85-115	85-113	85-114	85-113	3/8
	Wide	85-111A	85-115A	85-113A	85-114A	85-113A	3/4
	Tapered	85-111B	85-115B	85-113B	85-114B	85-113B	
52	Standard	85-91	85-92	85-93	85-94	85-93	1/2
	Wide	85-91A	85-92A	85-93A	85-94A	85-93A	1
	Tapered	85-91B	85-92B	85-93B	85-94B	85-93B	1
60	Standard	85-7		85-20	85-7	85-115	3/8
	Wide	85-7A		85-20A	85-7A	85-115A	3/4
	Tapered	85-7B		85-20B	85-7B	85-115B	3/4
61	Standard	85-17		85-18	85-17	85-43	1/2
	Wide	85-17A		85-18A	85-17A	85-43A	1
	Tapered	85-17B		85-18B	85-17B	85-43B	1
62	Standard	85-65	85-43	85-66	85-67	85-66	1/2
	Wide	85-65A	85-43A	85-66A	85-67A	85-66A	1
	Tapered	85-65B	85-43B	85-66B	85-67B	85-66B	1
601	Standard	85-77	85-77	85-77	85-77	85-95	1/2
	Wide	85-77A	85-77A	85-77A	85-77A	85-95A	1
	Tapered	85-77B	85-77B	85-77B	85-77B	85-95B	1
602	Standard	85-46	85-46	85-46	85-46	85-46	1/2
	Wide	85-46A	85-46A	85-46A	85-46A	85-46A	1
	Tapered	85-46B	85-46B	85-46B	85-46B	85-46B	1
626 lot A	Wide			85-124A	85-123A	85-124A	1
626 lot B	Wide			85-125A	85-126A	85-125A	1

Tool Slide Mounted Wickman

#	Machine	Style	Capacity	1	2	3	4	5	6	7
5	1 3/4, 2 1/4	Wide	13/32 - 1 1/4	85-64A	85-61A	85-62A	85-63A			
		Tapered		85-64B	85-61B	85-62B	85-63B			
6	1	Standard	0 - 1	85-142	85-142	85-142	85-142	85-142		
	1 3/8, 1 3/4	Wide	13/32 - 1 1/4		85-71A	85-71A	85-56A	85-56A		
		Tapered			85-71B	85-71B	85-56B	85-56B		
8	1	Standard						85-141	85-140	
	1 3/4	Standard					85-110	85-85	85-35	85-122

Advanced Insert System Reduces Downtime, Improves Quality

Our customers talked. We listened. The results have been impressive. Our new Direct Mount™ Insert technology works hand-in-hand with setup reduction programs to improve machine utilization. Screw-on inserts eliminate tool adjustments at tool change and allow excellent chip flow and coolant access to the cutting edge. Mount directly to our new G-Series Shaving System or use a dovetail adapter with older shave tool holders and dovetail form tool holders.

Case History: Berkley Screw

Like most companies, Berkley Screw used our original pin-style shave tool holder with dovetail HSS tooling. Quality and uptime were both considered acceptable. We replaced their traditional shave tool system with a new G-Series™ Shaving System with Direct Mount™ Inserts. The results were impressive. Initial surface finish approached the quality of a ground part while tool life soared. With the older holder, Berkley had to adjust for diameter once a shift as the tool either wore or was replaced with a new tool. After switching to our advanced shaver, diameter adjustments were eliminated.

Inserts blanks are available from stock for those who EDM their own tools, or we can finish EDM the tooling for you and guarantee tool-to-tool deviation of less than $\pm .0005$ " with tighter tolerances within the form. Each job has a dedicated tool post or adapter, guaranteeing the integrity of the setup and making for quick changeovers.

Customers have two choices in materials: An extremely tough micro-grain carbide or a specialty high-alloy PM tool steel which is as tough as T-15 but about 8% harder, it yields better part finishes with about the same grindability as T-15.

What's New in Shaving

Our new G-Series shaving system has innovative features which improve the shaving process. A tighter, smoother float handles chatter better and stands up to abuse. One customer accidentally proved the strength of the new G-Series™ Shaving System when their form tool wasn't clamped during the initial setup. The customer shaved .600" off the diameter of hundreds of parts with no damage to the holder or the tool. The only sign of trouble was a small heat blemish on the part. The part was perfectly sized.

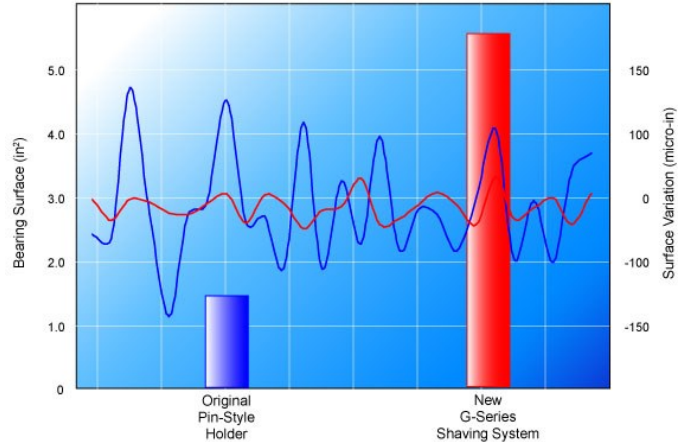

New G-Series Shaving System with Direct™ Mount

Actual Results

Material: 12L14

Machine: Model 62 New Britain

	Before	After
Microfinish (new tool)	45 Ra	9 Ra
Microfinish (at tool change)	120 Ra	65 Ra
Pieces per edge	5,000	70,000
Shifts to tool change	2	24
Holder adj per shift	1	0

Our Advanced Direct Mount™ Tooling System is engineered for both forming and shaving. Screw on inserts have all the ease and repeatability of standard ISO inserts, excellent chip flow and no blind pockets for chips to accumulate

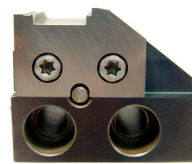

Typical Shaving Application
Tool Post & Insert



Dovetail Form Adapter
w/o Insert

Are you ready for a change? Direct Mount™ is Easy, Fast and Reliable. Call for details.

- Improve part quality & finish.
- Reduce downtime from tool changes.
- Reduce tool inventory & safety stock.
- Eliminate Operator Error in Tool Change.
- Decrease Tooling Lead Times.

Perishable Tooling - Do it yourself Inserts!

You machine your own dovetail tooling, now machine your own inserts...

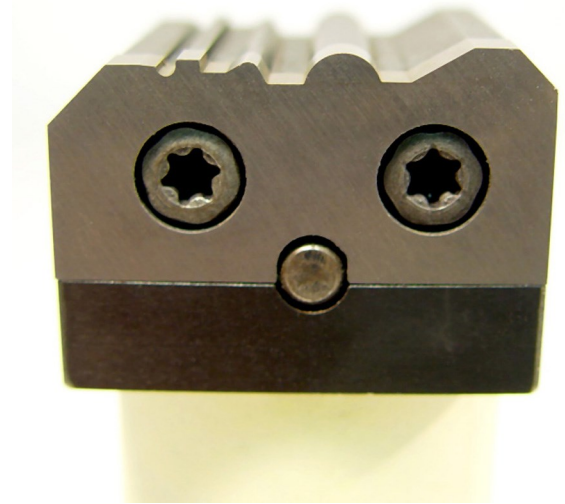

Features & benefits

- Lower your tooling costs by moving to replaceable inserts... One insert blank replaces multiple form and shave blanks with various dovetail sizes, offsets and rake angles. You'll reduce your tooling inventory dramatically. Instead of buying dovetail blanks that might sit for months (or more), your inserts will work with multiple jobs and never go unused. We found that we could replace 39 standard dovetail form blanks and 99 standard shave blanks with only 3 different inserts.
- Are you buying inserts but making your own dovetail tools? Save money and time by finish machining insert blanks in-house. End the frustration of uncertain delivery times and communication errors. Get what you want when you want every time. You control the process!
- Simplify your perishable tooling... worry only about the length of the part. Our patent pending insert system works with any dovetail size, any offset, any rake angle, any tool length, and part lengths up to 2". Custom sizes are available.
- You'll save time and money finishing your tools because inserts machine faster than dovetail tools, improving turnaround on all jobs in the shop. Operators and quality control staff both agree that inserts improve both quality and machine utilization.
- One standard Schlitter insert blank can be used for any offset, any rake angle, any tool length and any part width up to 2" wide. We found that we can cover a range of 39 standard dovetail form tool blanks and 99 standard dovetail shave tool blanks with only 3 insert blanks. That's a huge savings by any standard.
- Works with any datum system.
- We provide the insert blanks, engineering support, EDM fixturing, adaptive form tool holders and our advanced G-Series shaving system.

Need Tooling? We can help!

Get your tooling from the industry experts. Our tooling is accurate and highly repeatable. Our zero-defect process creates extremely accurate profiles on-time, every time. Call today

Perishable Tooling - Do it yourself Inserts Blanks

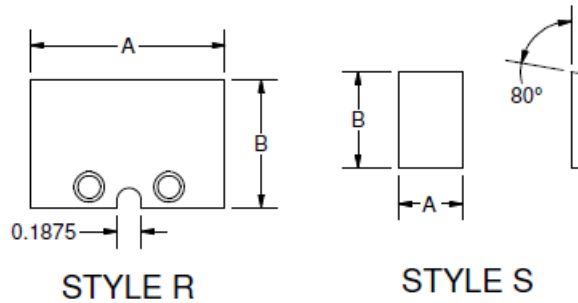

Part #	Insert Style	Thickness	A	B	C	Hole Size	Material Spec	Notes
R1501-CZ	R	0.1875	1.52	1.000		4mm ISO	High Grade Carbide	
R1501-MX	R	0.1875	1.52	1.000		4mm ISO	Heat Treated HSS	
R2001-CZ	R	0.1875	2.02	1.000		4mm ISO	High Grade Carbide	
R2001-MX	R	0.1875	2.02	1.000		4mm ISO	Heat Treated HSS	
R2501-MX	R	0.1875	2.52	1.000		4mm ISO	High Grade Carbide	
R3001-MX	R	0.1875	3.02	1.000		4mm ISO	Heat Treated HSS	
1395-BLANK	S	0.125	.5000/.4995	.7495/.7490		n/a	High Grade Carbide	J Polished Top Surface, Exterior Sizes Finished, with 10 deg on Cutting Edge

Cross Slide Flat Generating & Thread Milling - Polygon Turning

Make it complete!

- Heavy Duty attachment allows for machining in steel
- Attachment Drives 1:1 or 2:1 with change gears, allowing core attachment to both Thread Mill and Flat Generate
- Heat Treated Gears and Components
- Drives of Standard Spindle Drive Shaft Pickoff Gear
- Flat Generating cutter uses Carbide Inserts
- Attachment can be mounted in different positions by change the base plate
- Thread Milling Attachment has taper adjustments for exact pitch straightness
- Outboard transmission allows room for drill saddle to be mounted on the tool slide in the same position
- Handles "Behind Shoulder Flats" that eliminates Secondary Operations

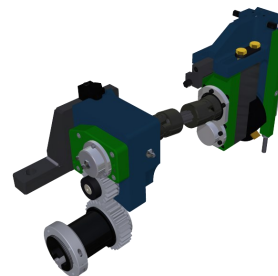
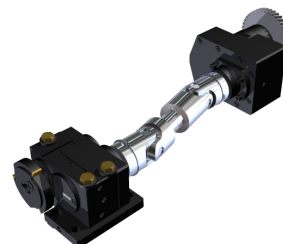

	R - 6000 - 002	
Machine Size		Position*
B - 9/16"RA-6 Acme		002
D - 1"RA-6 Acme		003
F - 1 1/4" RA-6 Acme		004
I - 1 5/8"RB-6 Acme		005
L - 2 5/8"RB-6 Acme		006
P - 3/4"RA-8 Acme		007
R - 1 1/4"RB-8 Acme		
V - 1 5/8"RBN-8 Acme		
S - 1 5/8"RB-8 Acme		
T - 2"RB-8 Acme		
U - 2 5/8"RB-8 Acme		
WI58 - 5/8"-6 Wickman		
WI138 - 1 3/8"-6 Wickman		
WI134 - 1 3/4"-6 Wickman		
WI1 - 1"-8 Wickman		
NB51 - Model 51 New Britain		
NB52 - Model 52 New Britain		
NB62 - Model 62 New Britain		
NB812 - Model 812 New Britain		
DV - Davenport		
		Attachment Type
		6000 - 2:1 Flat Generating
		6001 - 1:1 Thread Milling
		6003 - 1:1 Flat Generating

When ordering for Acmes, Please inform BME if your machine is a synchronous machine

Please inform BME what RPM your work spindle will be running

*Notes on Positions -

Acme Six Spindles are available in Positions 2, 3, and 4
 Acme Eight Spindles are available in Positions 3, 4, 5, 6
 New Britain and Wickman Six Spindles are available in Positions 3,4,5
 New Britain and Wickman Eight Spindles are available in Positions 3,4,5,6
 Davenport Models are only available in Position 4 - Please specify if threading is also being used.
 For best results, BME recommends keeping cross slide feed cam at .0005"/rev or below

Not seeing your Machine size? Contact us, specials are available!

Synchronous ETS Cross Drill

Make it complete!

- Heavy Duty attachment allows for machining in steel
- Drill Cross Holes without stopping the spindle
- Quick Change Drill Cap Assy for fast and easy tooling change
- Simple individual depth adjustments for Drill
- Patent Pending Design
- Drill 1 to 4 Holes
- RH Tooling
- Drill Strokes up to .400"
- RPM Ratio (Drill to Work Spindle) 1.25:1 Feed Ratio (MTS / Drill Feed) 1.0:.414
- Max Drill Diameter of Part to be drilled—1.25"
- Requires 1:1 Pickoff Drive Unit, not included

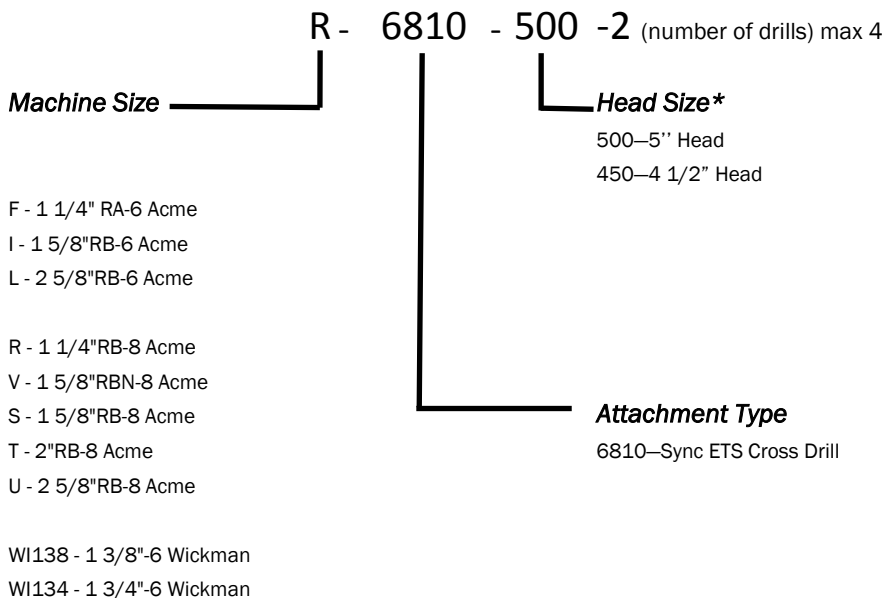
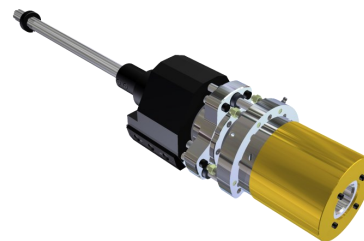

Please inform BME what RPM your work spindle will be running

***Notes on Positions -**

- * 1 3/8"-6 Wickman requires an alteration to the machine tool slide to use 5" Head, 4 1/2" head fits
- * Max Head on 52 New Britain is a 4 1/2".

Not seeing your Machine size? Contact us, specials are available!

Synchronous End Tool Slide Milling Attachments

Make it complete!

- Fits most multi spindles automatics
- Heavy Duty Ball Bearing Construction
- Face Plate System allows Support Bushings
- High Pressure Coolant Ports
- Hardened and Ground Components
- No Line Boring Required
- Requires 1:1 Pickoff Drive Unit, not included

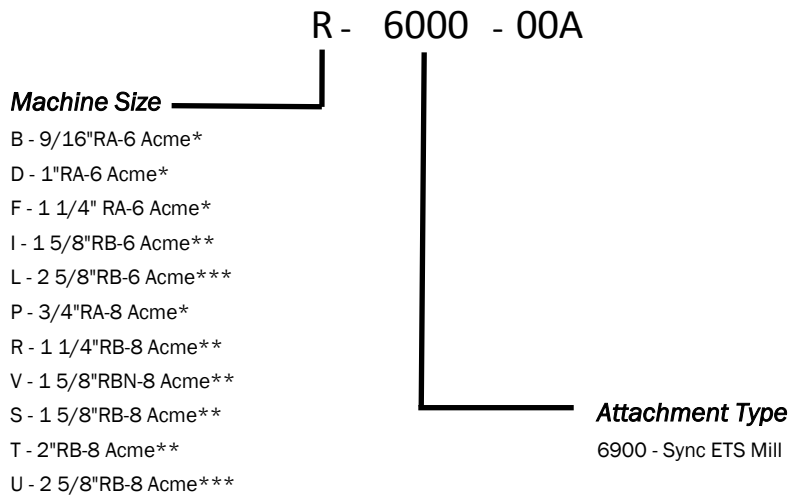
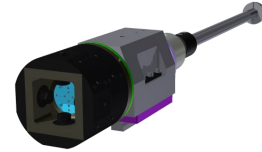

W1138 - 1 3/8"-6 Wickman**
W1134 - 1 3/4"-6 Wickman**

NB52 - Model 52 New Britain*
NB62 - Model 62 New Britain*
NB812 - Model 812 New Britain*

Please inform BME what RPM your work spindle will be running

***Notes on Positions -**

- *3" Body—Max 3" Cutter w/ 1" Arbor
- ** 4.5 Body—Max 4 1/2" Cutter w/ 1" Arbor
- *** 5" Body—Max 5 1/2" Cutter w/ 1" Arbor

Not seeing your Machine size? Contact us, specials are available!

New Britain Air

Operated Pick Off Assemblies Make it complete!

- Units available for Model 51, Model 52, and Model 62 New Britains
- Completely Pneumatic Piston, including air blow out, “Acme” style Pickoff
- Utilizes National Acme Pick Off collets
- Hardened and Ground Components
- Sealed Bearings, included the front angular contact bearing
- Unit comes with Housing and Spindle, Drive Unit, and Safety Link Assy with Elec Jam Switch
- Utilizes Existing Standard New Britain Feed Lever and Linkage (not provided)
- Boring Bar adapter available
- Pneumatic control packages available
- Installation available

Machine Size	Complete Assy #	Nat'l Acme Collet #
Model 51 New Britain	NB51-2000	A0-2920 thru A0-2940 (1" Max)
Model 52 New Britain	NB52-2000	JM-2920 thru JM-2940 (1 1/4" Max)
Model 62 New Britain	NB62-2000	AW-2920 thru AW-2940 (2" Max)

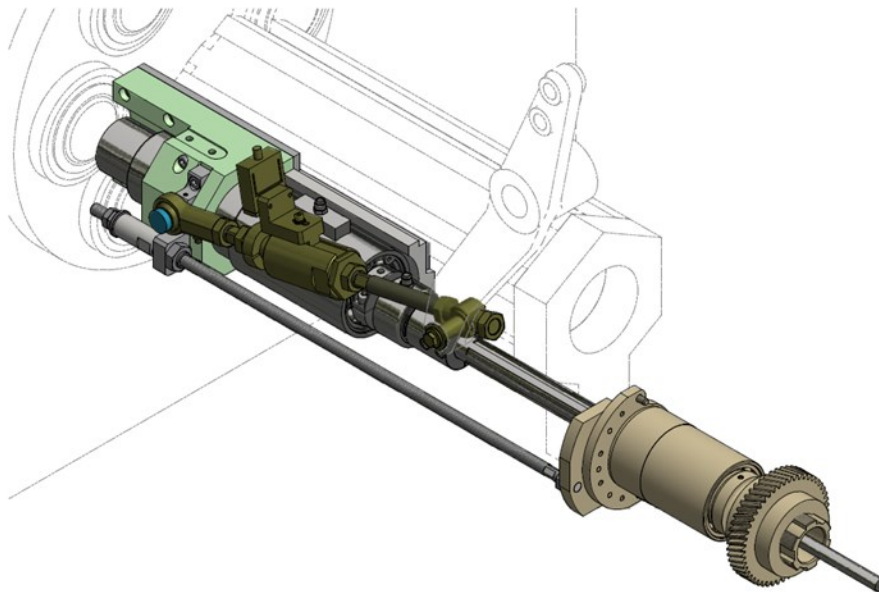

Not seeing your Machine size? Contact us, specials are available!

Cross Slide Recess Attachments / Face Grooving

Make it complete!

- Designed and Manufactured for Acmes, New Britains, Wickmans, and more
- Mounts on Cross Slide,
- Unit can be purchased to feed toward the spindle or away from the spindle
- Provides a solution to cutting grooves, trepans, and under cuts

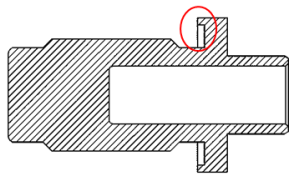
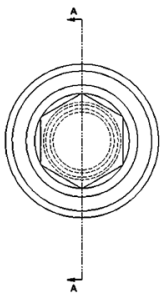
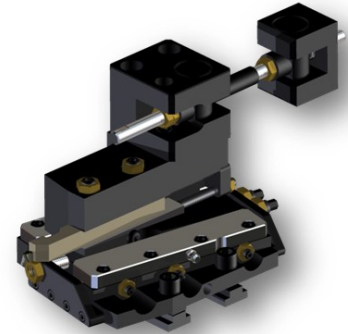

SECTION A-A
SCALE 3:1

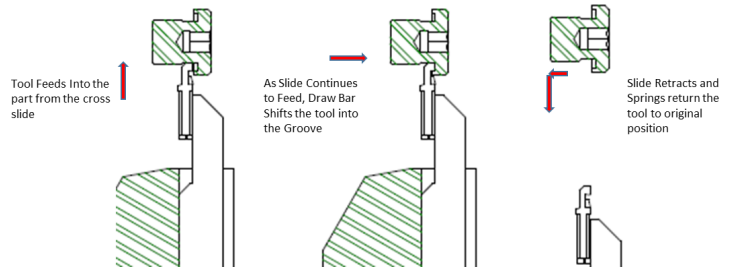

Contact BME for Pricing and Availability!

Ball Bearing Style High Speed Drilling Spindles

- Precision Spindle Bearings replace traditional plain bearings and ball thrust bearing, allowing for proper end play, and better tool performance and tool life
- Spindle comes with ER collet seat, allowing for easier change over between drill sizes, and better tool performance and tool life
- 2 piece drive shaft construction allows for easier installation

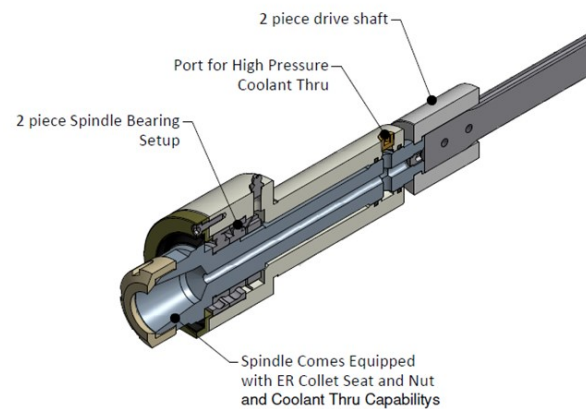

Contact BME for Pricing and Availability!